

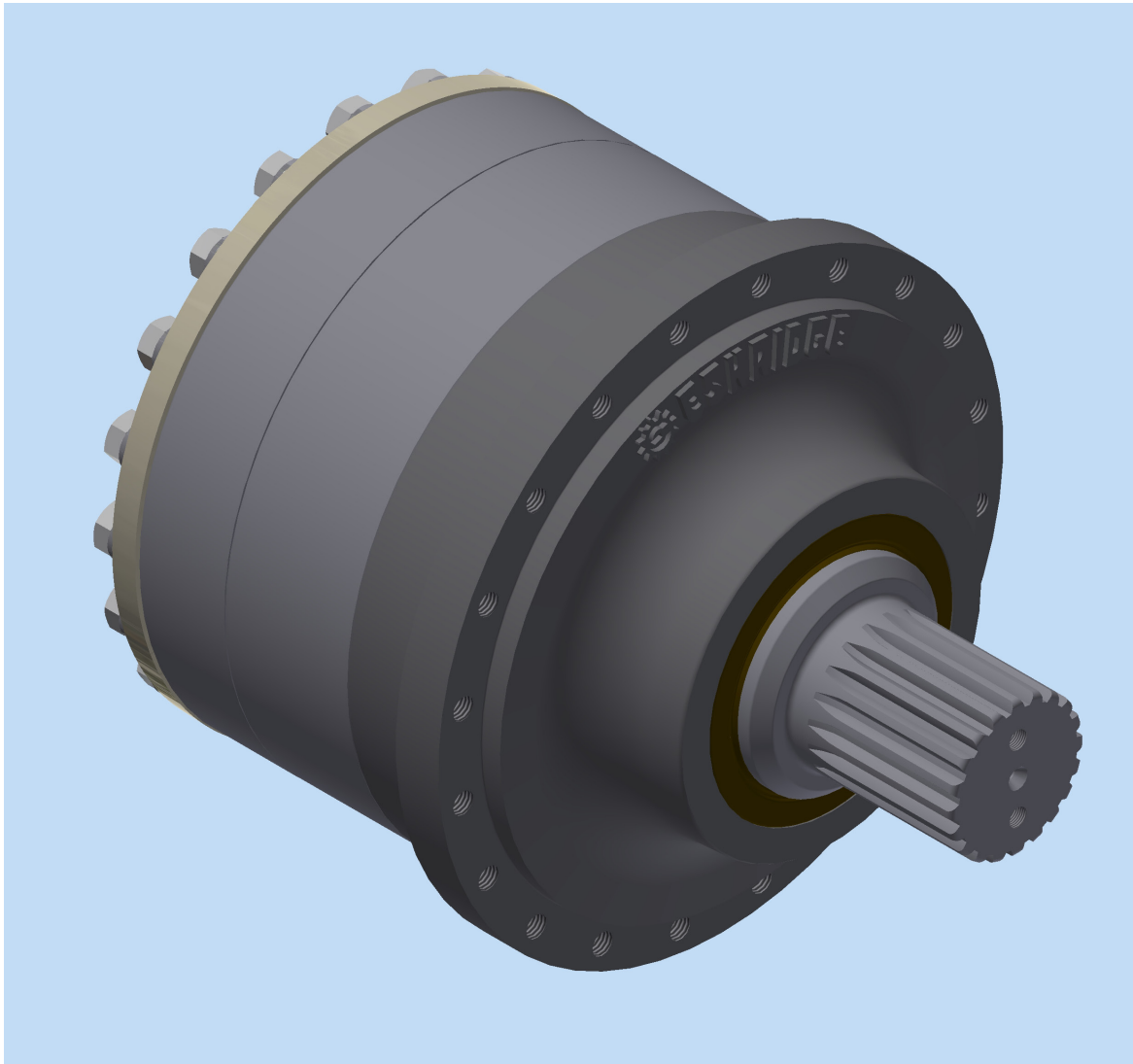

MODEL 310L PLANETARY GEAR DRIVE SERVICE MANUAL



WARNING: While working on this equipment, use safe lifting procedures, wear adequate clothing and wear hearing, eye and respiratory protection.

THIS SERVICE MANUAL IS EFFECTIVE:
S/N: 74300 TO CURRENT
DATE: 08/04/2007 TO CURRENT
VERSION: SM310L-BA

NOTE: Individual customer specifications (mounting case, output shaft, brake assembly, etc.) may vary from exploded drawing and standard part numbers shown. If applicable, refer to customer drawing for details.

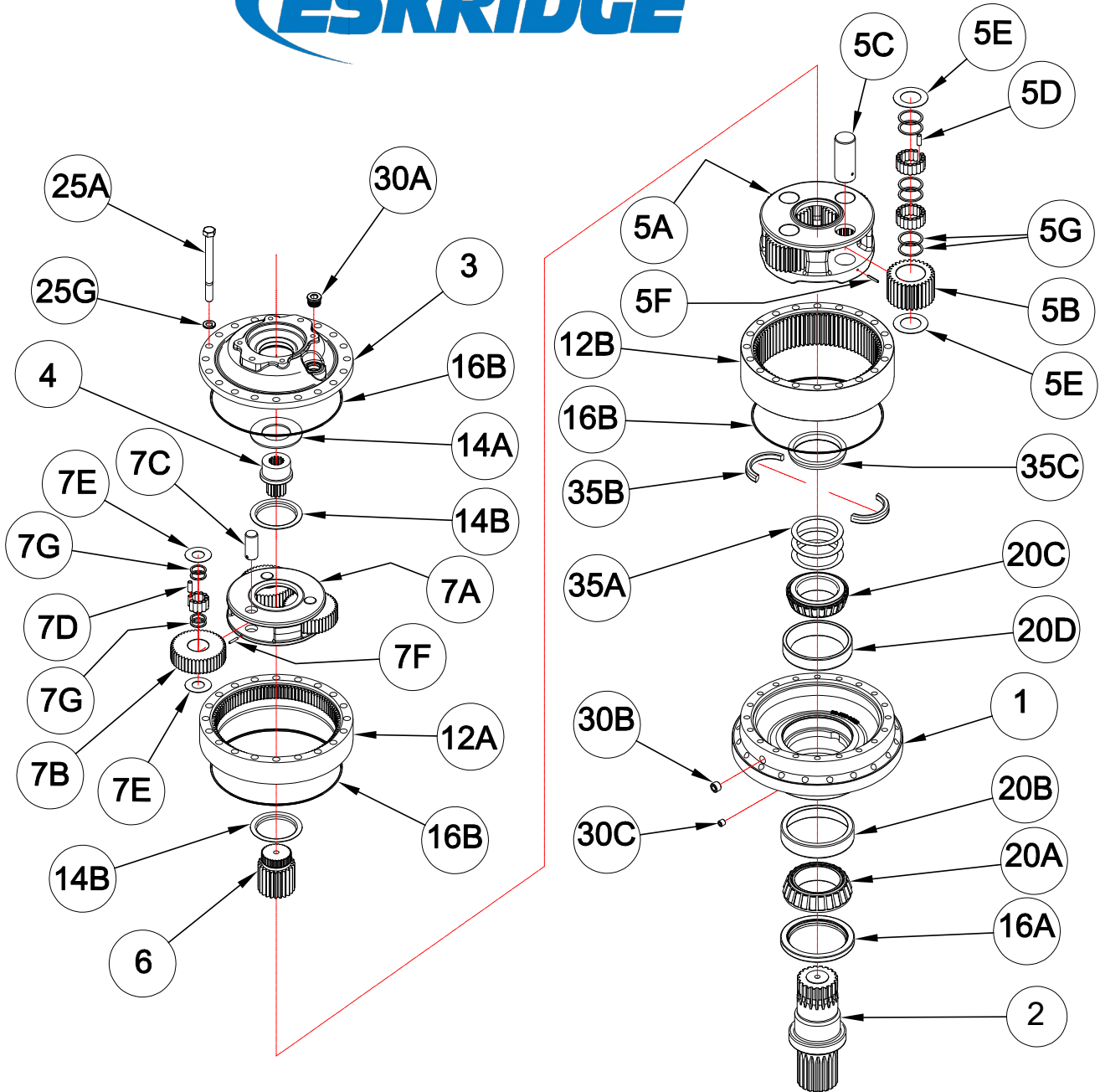



MODEL 310L

EQUIPPED WITH
"LOAD-N-LOCK" SHAFT
RETENTION SYSTEM

ITEM	QTY	EFFECTIVE: FROM: S/N 74300 08/04/07 TO: CURRENT	RATIO →			
			20.25:1 4.3125:1 4.6957:1	26.34:1 5.609:1 4.6957:1	29.58 6.3:1 4.6957:1	40.24:1 8.57:1 4.6957:1
		DESCRIPTION	PART NUMBER			
1	1	250A BASE - ROUND	25-004-3042			
		250F BASE - FLANGELESS	25-004-3052			
		250Q BASE - ECCENTRIC PILOT	25-004-3132			
		CUSTOM BASE	-----			
2	1	D1 - OUTPUT SHAFT 20T 6/12 SPLINE	25-004-4032L			
		D2 - OUTPUT SHAFT 4.50" DIA, KEYED	25-004-4340L			
		C1 - OUTPUT SHAFT - CUSTOM	-----			
3	1	A - SAE 'A' COVER	25-005-2061			
		B - SAE 'B' COVER	25-005-2051			
		C - SAE 'C' (2 AND 4 BOLT)	25-004-1222			
		D - SAE 'D' COVER	25-004-1232			
4	1	INPUT GEAR - 14T-12/24 SPLINE	25-004-1732	25-004-1792	25-004-1742	25-004-1812
		INPUT GEAR - 13T-8/16 SPLINE	25-004-1762	25-004-1802	25-004-1772	25-004-1782
5		CARRIER ASSY - SECONDARY	25-005-2161			
5A	1	CARRIER - SECONDARY	25-004-1602			
5B	4	PLANET GEAR - SECONDARY	25-004-1632			
5C	4	PLANET SHAFT - SECONDARY	25-004-1432			
5D	144	ROLLER - 2 ROWS, 18 EACH ROW	01-106-0010			
5E	8	THRUST WASHER - SEC. PLANET	25-004-1462			
5F	4	ROLL PIN (3/16 X 1 1/4)	01-153-0190			
5G	24	SPACER - SEC PLANET BEARING	25-004-1975			
6	1	SUN GEAR - SECONDARY	25-004-1622			
7		CARRIER ASSY - PRIMARY	25-005-2201	25-005-2181	25-005-2211	25-005-2171
7A	1	CARRIER - PRIMARY	25-004-1692	25-004-1642	25-004-1702	25-004-1412
7B	3	PLANET GEAR - PRIMARY	25-004-1712	25-004-1652	25-004-1722	25-004-1552
7C	3	PLANET SHAFT - PRIMARY	25-004-1442			
7D	36	ROLLER - 12 ROLLERS/PLANET	01-106-0010			
7E	6	THRUST WASHER - PRI. PLANET	13-004-1582			
7F	3	ROLL PIN (3/16 X 1)	01-153-0020			
7G	12	SPACER - PRI PLANET BEARING	13-004-1592			
12A	1	RING GEAR - PRIMARY	25-004-1562			
12B	1	RING GEAR - SECONDARY	25-004-1612			
14	---	THRUST WASHERS AND THRUST BRGS	-----			
14A	1	THRUST WASHER - INPUT GEAR	25-004-1752			
14B	2	THRUST WASHER - CARRIER	25-004-1132			
16	(1)	SEAL KIT (INCLUDES ITEMS 16A, 16B)	25-016-2061			
16A	1	SHAFT SEAL	01-405-0740			
16B	3	SEAL (O-RING)	01-402-0020			
20	---	OUTPUT SHAFT BEARINGS	-----			
20A	1	BEARING CONE - OUTER	01-102-0120			
20B	1	BEARING CUP - OUTER	01-103-0110			
20C	1	BEARING CONE - INNER	01-102-0250			
20D	1	BEARING CUP - INNER	01-103-0250			
25	---	HARDWARE	-----			
25A	20	HEX HEAD CAPSCREW (5/8-11 X 7) GR 8	01-150-1630			
25G	20	LOCKWASHER - (5/8)	01-166-0040			
30	---	PLUGS	-----			
30A	1	PLUG - COVER	01-208-0030			
30B	1	PIPE PLUG (1/2 NPT MAGNETIC) - BASE	01-207-0041			
30C	1	PLUG 1/4 NPT	01-207-0020			
		GREASE FITTING (OPTIONAL)	01-215-0040			
35	---	MISCELLANEOUS	-----			
35A	*	SHIM - SHAFT ADJUSTMENT	25-004-1051			
35B	1	SPLIT RING- LOAD-N-LOCK	25-004-1182			
35C	1	LOCK RING - LOAD-N-LOCK	25-004-1192			

* QUANTITY OF SHIMS DETERMINED BY BEARING PRELOAD. X310LD2-Ba ECN: - DATE: 04-10-26 MTK

LUBRICATION & MAINTENANCE

Using the chart below, determine an appropriate lubricant viscosity. Use only EP (extreme pressure) or API GL-5 designated lubricants. Change the lubricant after the first 50 hours of operation and at 500 hour intervals thereafter. The gear drive should be partially disassembled to inspect gears and bearings at 1000 hour intervals.



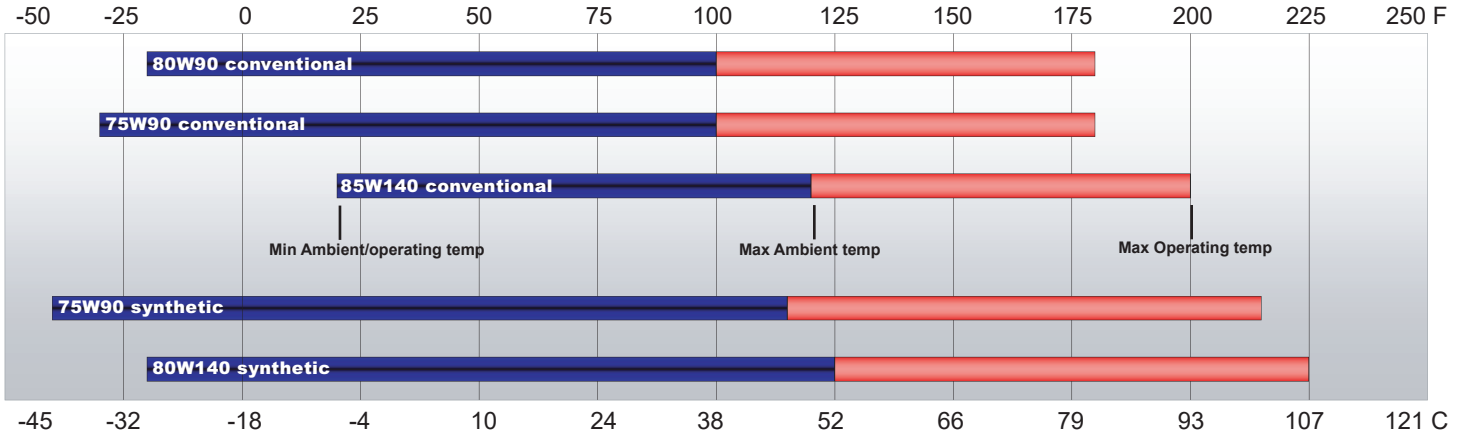



Recommended ambient and operating temperatures for conventional and synthetic gear lubricants



Note: Ambient temperature is the air temperature measured in the immediate vicinity of the gearbox. A Gearbox exposed to the direct rays of the sun or other radiant heat sources will operate at higher temperatures and therefore must be given special consideration. The max operating temp must not be exceeded under any circumstances, regardless of ambient temperature.

If your unit was specified "shaft up" or with a "-Z" option, a grease zerk was provided in the base housing. For shaft-up operation, the output bearing will not run in oil and must be grease lubricated. Use a lithium based or general purpose bearing grease sparingly every 50 operating hours or at regular maintenance intervals. Over-greasing the output bearing should be avoided as it tends to fill the housing with grease and thicken the oil

ESKRIDGE MODEL 310L OIL CAPACITIES

Operating Position	Oil Capacity	Oil Level
 Horizontal Shaft	3 qts / 2.8 l	To horizontal centerline of gear drive 
 Vertical Shaft (Pinion Up)	5 qts / 4.7 l	To side port on gear drive base 
 Vertical Shaft (Pinion Down)	5 qts / 4.7 l	To midway on upper/primary gear set 

ESKRIDGE PART NUMBER INTERPRETATION

Note: All non custom Eskridge Geardrives are issued a descriptive part number which includes information regarding the Model, means of shaft retention, base style, shaft style, input mounting, input shaft size, overall ratio and various available options. For a detailed breakdown of this information, please refer to Eskridge product specification sheets found at: <http://www.eskridgeinc.com/geardrives/gearprodspecs.html>

Unit Teardown

- 1) Scribe a line across the outside of the unit from the cover (3) to the base (1) before disassembly to aid in the proper positioning of pieces during reassembly.
- 2) Remove drain plugs (30A &/or 30B) and drain oil from unit. The oil will drain out more quickly and completely if warm.
- 3) Remove the twenty 5/8-11 capscrews (25A) and lockwashers (25G).
- 4) Remove the cover (3), and thrust washer(s) (14A & 14B), and input gear (4). Inspect o-ring (16B); discard if damaged or deformed.
- 5) Lift the planet carrier assembly (7) out of the unit and lift the primary ring gear (12A) off the unit.
- 6) Lift the secondary ring gear (12B) and o-ring (16B) from the gearbox. Inspect gear to base O-ring (16B); as before, replace if damaged or deformed.
- 7) Carefully lift the output-stage (secondary) carrier assembly (5) from the output shaft spline and set aside.
- 8) The unit is now disassembled into groups of parts. The area(s) requiring repair should be identified by thorough inspection of the individual components after they have been cleaned and dried.

Carrier Assembly Teardown

Rotate planet gears (7B pri/5B sec) to check for abnormal noise or roughness in bearings (7D pri/5D sec). If further inspection or replacement is required, proceed as follows.

- 1) Drive roll pins (7F pri/5F sec) completely into the planet shafts (7C pri/5C sec).
- 2) Slide planet shafts (7C pri/5C sec) out of carrier (7A pri/5A sec).
- 3) Remove planet gears (7B pri/5B sec), washers (7E pri/5E sec), spacers (7G pri/5G sec) and bearings (7D pri/5D sec) from carrier (7A pri/5A sec).
- 4) Inspect the planet gear (7B pri/5B sec), bearing bore and planet shaft (7C pri/5C sec) and bearing rollers (7D pri/5D sec). Check for spalling, bruising or other damage and replace components as necessary. *Note: When using loose (uncaged individual) rollers, all rollers in the planet gear must be replaced if any are found to be defective (and likely the planet shaft and planet gear as well).*
- 5) Remove roll pins (7F pri/5F sec) from planet shafts (7C pri/5C sec) using a 3/16 inch pin punch.

Carrier Reassembly

- 1) Loose roller installation:
 - a) Set planet washer (7E pri/5E sec) on work table with planet gear (7B pri/5B sec) on top of it. Center planet washer to planet gear as closely as possible.
 - b) Center planet shaft (7C pri/5C sec) in planet gear (7B pri/5B sec) bearing bore.

- c) If used, place spacer washer (7G pri/ 5G sec) onto planet shaft (refer to exploded view to confirm spacer positions).
- d) Begin placing rollers (7D pri/5D sec) around shaft (7C pri/5C sec). There should be clearance for last roller to slide in. Be sure to install 12 (pri) or 2 rows of 18 (sec) rollers in each planet gear (7B pri/5B sec) on loose roller applications.

(If using multiple rows of rollers, repeat steps C and D as necessary. Once complete, refer to exploded view to confirm that any spacer washers (7G pri/ 5G sec) are appropriately placed.)
- e) Place a washer (7E pri/5E sec) over gear (7B pri/5B sec) and onto shaft (7C pri/5C sec).
- f) Carefully slide assembly off of table, holding planet washers (7E pri/5E sec) against planet gear (7B pri/5B sec).
- g) Slide planet shaft (7C pri/5C sec) out of the assembly and slide assembly into carrier.
- h) Align planet gear & bearing assembly inside carrier and install planet shaft through entire assembly. Use grease to hold the rollers if necessary.

- 2) Planet shafts (7C pri/5C sec) should be installed with chamfered end of 3/16 inch roll pin hole towards outside diameter of carrier (7A pri/5A sec); this will ease alignment of holes while inserting roll pins (7F pri/5F sec).
- 3) Drive roll pin (7F pri/5F sec) into the carrier hole and into planet shaft to retain parts. Repeat for remaining planet gears.

Base Subassembly Teardown

- 1) Remove the lock ring (35C) using a heel bar or puller; if using a heel bar, be sure **not** to pry against the cage of the inner output shaft bearing (20C). Remove the split ring segments (35B) and shims (35A).

Caution: Since the shaft is no longer positively retained, care should be taken to avoid personal injury. Care should also be taken not to damage the shaft while pressing through base.

Note: Removing the shaft from the base assembly damages the shaft seal (16A) and the seal will need to be replaced.

- 2) Place base (1) external side down, on a plate or table. Press output shaft (2) out bottom of base (1) by applying a load to internal end of shaft until it passes through inner shaft bearing cone (20C).
- 3) A gear puller may be used to remove the outer bearing cone (20A) from the shaft (2). If reusing old bearing cone, do not pull on or damage roller cage. Remove the shaft seal (16A) and replace .
- 4) Inspect inner and outer bearing cups (20D & 20B). If cups are damaged, drive them out using a brass drift and utilizing the bearing knock-out notches in the base (1)

Base Reassembly

- 1) Clean all foreign material from any magnetic oil plugs located on base **(1)**.
- 2) Place base **(1)** exterior side up on work table.
- 3) Apply a layer of lithium or general purpose bearing grease to the roller contact surface of outer bearing cup **(20B)**.
- 4) Press outer bearing cone **(20A)** onto the shaft **(2)** until it seats against the shoulder.

Note: Press bearing cone onto output shaft by pressing on inner race only. DO NOT press on roller cage, as it will damage bearing.

- 5) Place the shaft **(2)** with the bearing **(20A)** into the base **(1)**.
- 6) Lubricate inner lip of new shaft seal **(16A)** and slide it onto the shaft **(2)** until it fits snugly over the shaft seal diameter with the open side toward the inside of the gear drive.
- 7) Flip shaft/base assembly, and apply lithium or general purpose bearing grease to roller contact surface of the inner cup **(20D)**., then press inner bearing cone **(20C)** onto shaft **(2)** until it seats against inner bearing cup **(20D)**. Spin the base as you do this to gage the pre-load on the bearing.
- 8) Prior to installation of the shaft seal **(16A)**, the pre-load may result in a rolling torque which varies between 100 to 400 in-lb. The bearing preload should be tailored to your application; a low-speed application may require a high pre-load, while high-speed applications usually benefit from low pre-load. Adding shims **(35A)** will increase the pre-load on the bearing set. Determine your pre-load requirement and install shims **(35A)** to obtain this pre-load.
- 9) Install the Load-N-Lock™ segments **(35B)** over the shims **(35A)** and into the groove in the shaft **(2)**. Finally, install the lock ring **(35C)** over the segments **(35B)**.

All subassembly service or repairs should be complete at this time. Continue to Unit Assembly to complete unit buildup.

Unit Reassembly

- 1) Install the secondary carrier **(5)** assembly onto the output shaft **(2)**; align the splines of the carrier **(5A)** with the output shaft **(2)** splines and slide the carrier onto the shaft.
- 2) Lubricate o-ring(s) **(16B)** and install on the ring gear **(12B)** pilot.

Caution: Hold ring gear(s) by outside diameter or use lifting device to prevent injury.

- 3) Align gear teeth of secondary ring gear **(12B)** with the gear teeth of the planet gears **(5B)** and then align the bolt holes; also use the scribe-mark made during disassembly and work the ring gear onto the base **(1)**.
- 4) Lubricate another o-ring **(16B)** and install onto the pilot of the primary ring gear **(12A)**.
- 5) Install the sun gear **(6)** into the secondary carrier **(5)**. Install the primary ring gear **(12A)** into the pilot of the secondary ring

gear **(12B)** and align the bolt holes.

- 6) Install the thrust washer **(14B)** onto the upper hole of the secondary carrier assembly **(5)**. Install the input stage (primary) carrier assembly **(7)**. Align the gear teeth of the planets **(7B)** with the ring gear teeth **(12A)** and finally as it slides down align the splines of the carrier **(7A)** with the splines of the sun gear **(6)**.
- 7) Install the second thrust washer **(14B)** into the upper hole of the primary carrier **(7A)**. Install the input gear **(4)**.
- 8) Install the thrust washer **(14A)** Refer to exploded view for details.
- 9) Lubricate the final o-ring **(16B)** and install it on the pilot of the cover **(3)**.
- 10) Noting the scribed line made during disassembly, (with lubricated o-ring **(16B)** in place) align and install the cover **(3)**.
- 11) Install and torque the 20 5/8-11 hex-head cap-screws **(25A)** with lockwashers **(25G)**. The torque for the cap-screws: **220 ft-lb dry, 170 ft-lb lubed.**
- 12) Using a splined shaft to drive the input gear **(4)** ensure that the unit spins freely.
- 13) Fill the unit to the proper level, as specified, with recommended gear oil (refer to chart, page 3) after unit is sealed with brake and/or motor.

The gearbox is now ready to use.