



1400 GEAR DRIVE - WHEEL DRIVE

1,400,000 in-lb (158,179 N-m) Intermittent Rating 700,000 in-lb (79,089 N-m) Continuous Rating
 Typical Applications: Industrial, Marine or Mobile Equipment

(913) 782-1238 (Tel)
 (913) 782-4206 (Fax)
 Sales@Eskridgeinc.com
 www.Eskridgeinc.com
 FORM: PS1400WD-AE
 SHEET 1 OF 4

1400 2-Stage General Dimensions Flanged 'A' Option (Shown Without Disconnect)

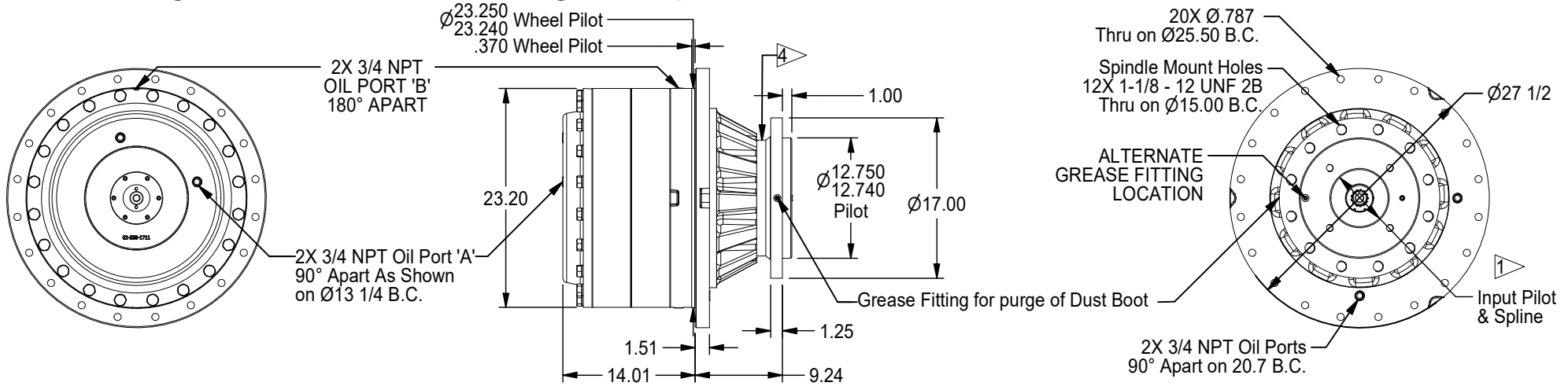

1400 2-Stage General Dimensions Flangeless 'F' Option (Shown With Disconnect)

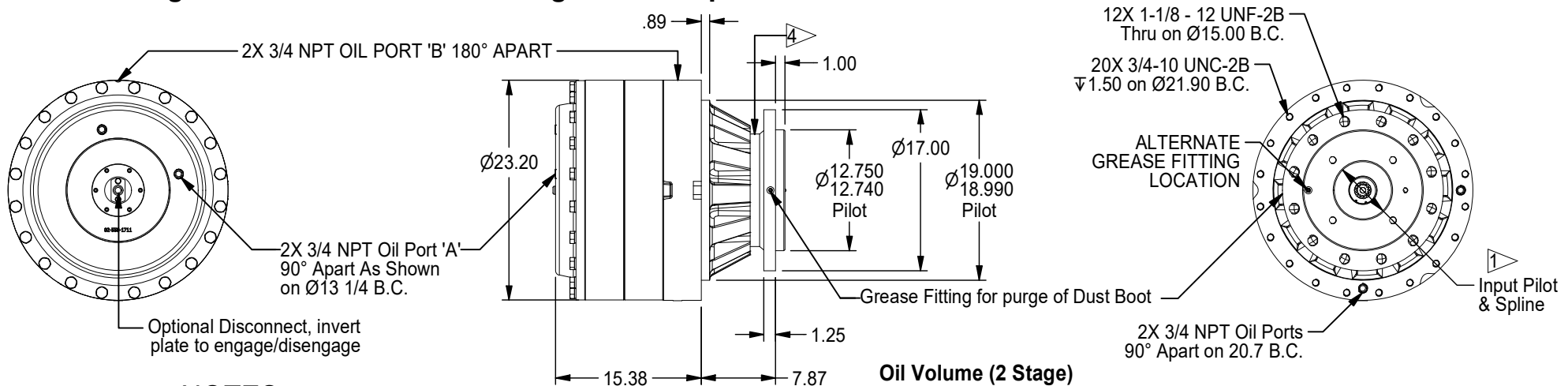

NOTES:

1. SPECIFICATIONS CALLED OUT IN MOTOR MOUNT DIMENSIONS SECTION.
2. VALUES ARE SHOWN IN INCHES.
3. OUTPUT SHAFT ROTATION OPPOSITE OF INPUT ROTATION.
4. METAL FACE SEAL WITH RUBBER BOOT.

Oil Volume (2 Stage)

LUBRICATION QUANTITY	HORIZONTAL:	VERTICAL: PINION DOWN	VERTICAL: PINION UP
QUANTITY	4.5 Gal	7.5 Gal	7.5 Gal
OIL FILL LEVEL (GRADE GL-5 EP 80/90)	FILL TO: PORT 'A'	FILL TO: 1.5" FROM COVER PORT 'A'	FILL TO: PORT 'B'

All Units Shipped Without Oil



1400 GEAR DRIVE - WHEEL DRIVE

1,400,000 in-lb (158,179 N-m) Intermittent Rating 700,000 in-lb (79,089 N-m) Continuous Rating
 Typical Applications: Industrial, Marine or Mobile Equipment

(913) 782-1238 (Tel)
 (913) 782-4206 (Fax)
Sales@Eskridgeinc.com
www.Eskridgeinc.com
 FORM: PS1400WD-AE
 SHEET 2 OF 4

1400 3-Stage with 254 First Stage (Base Dimensions Identical to 2-Stage Option)

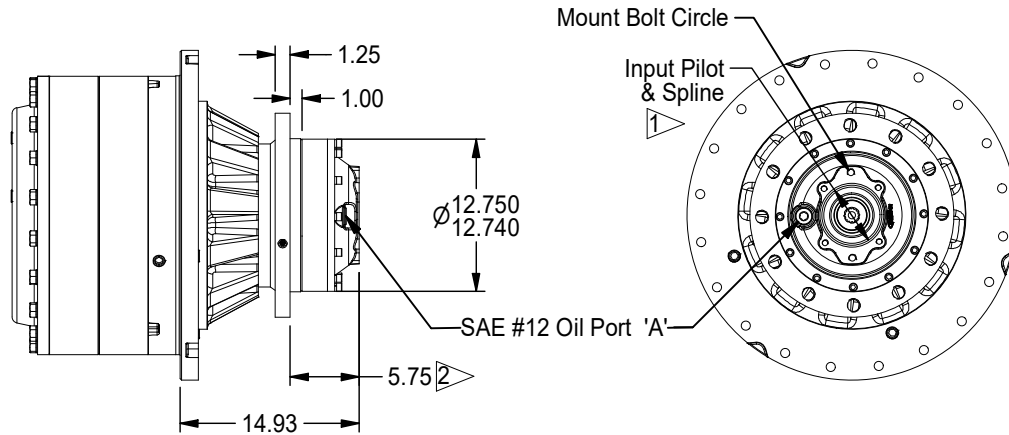

Available Ratios:	Input Mounting:	Input Spline:
110 109.89:1	SAE "A" (2 & Modified 4 Bolt)	4 (14T 12/24 DP Spline)
143 142.93:1	SAE "B" (2 & 4 Bolt)	9 (13T 8/16 DP Spline)
161 160.54:1	SAE "C" (2 & 4 Bolt)	
174 174.28:1	SAE "D" (4 Bolt)	
218 218.42:1		
227 226.66:1		
255 254.59:1		
346 346.39:1		

(Other Ratios Available)
 Consult Eskridge
 Representative

Oil Volume (3 Stage with 254 Primary)

LUBRICATION	ORIENTATION	HORIZONTAL:	VERTICAL: PINION DOWN	VERTICAL: PINION UP
QUANTITY		5.4 Gal	10.6 Gal	10.6 Gal
OIL FILL LEVEL (GRADE GL-5 EP 80/90)		FILL TO: PORT 'A'	FILL TO: 1.5" FROM COVER PORT 'A'	FILL TO: PORT 'B'

All Units Shipped Without Oil

NOTES:

- SPECIFICATIONS CALLED OUT IN MOTOR MOUNT DIMENSIONS SECTION.
- SAE 'D' MOUNT 6.43"



1400 GEAR DRIVE - WHEEL DRIVE

1,400,000 in-lb (158,179 N-m) Intermittent Rating 700,000 in-lb (79,089 N-m) Continuous Rating
 Typical Applications: Industrial, Marine or Mobile Equipment

(913) 782-1238 (Tel)
 (913) 782-4206 (Fax)
 Sales@Eskridgeinc.com
 www.Eskridgeinc.com
 FORM: PS1400WD-AE

SHEET 3 OF 4

Performance Ratings

Maximum Intermittent Output Torque: 1,400,000 in-lb (158,179 N-m)
 Continuous Output Torque: 700,000 in-lb (79,089 N-m)
 Maximum Input Speed: 4,000 RPM
 Maximum Operating Ambient Temperature: 110° F (43° C)
 Minimum Operating Ambient Temperature: -20° F (-28° C)

Consult your Eskridge representative to determine ratings for your specific application or configuration

Motor Mount Dimensions

PILOT DIMENSIONS	BOLT CIRCLE
SAE 'A' Ø3.250/3.254	2 & 4X 1/2-13 UNC-2B ∇5/8 ON Ø4.188 B.C.
SAE 'B' Ø4.001/4.005	2X 1/2-13 UNC-2B ∇.50 ON Ø5.75 B.C.
SAE 'C' Ø5.001/5.004	4X 1/2-13 UNC-2B ∇1 ON Ø6.375 B.C. 2X 5/8-11 UNC-2B ∇1 ON Ø7.125 B.C.
SAE 'D' Ø6.000/6.004	4X 3/4-10 UNC-2B ∇1 ON Ø9.000 B.C.

Approximate Unit Weight

Single Stage: 1,200 lb (544 kg)
 Two Stage: 1425 lb (648 kg)
 Three Stage: 1,700 lb (771 kg)

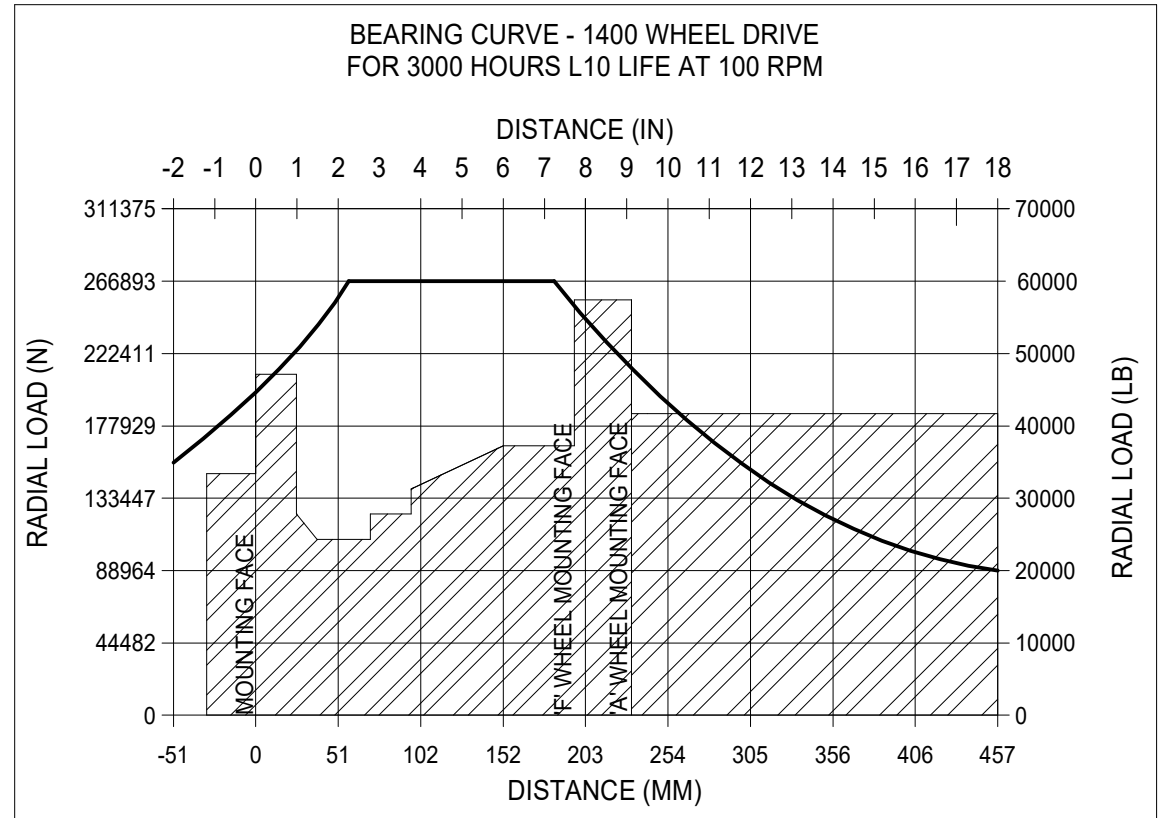

To adjust for loads and speeds other than those shown on above curve, use this formula:

$$\text{Adjusted Life (hours)} = 3000 \left(\frac{100 \text{ rpm}}{\text{Speed (Adjusted)}} \right) \times \left(\frac{\text{Load (Curve)}}{\text{Load (Adjusted)}} \right)^{10/3}$$



1400 GEAR DRIVE - WHEEL DRIVE

1,400,000 in-lb (158,179 N-m) Intermittent Rating 700,000 in-lb (79,089 N-m) Continuous Rating
Typical Applications: Industrial, Marine or Mobile Equipment

(913) 782-1238 (Tel)
(913) 782-4206 (Fax)
Sales@Eskridgeinc.com
www.Eskridgeinc.com
FORM: PS1400WD-AE

SHEET 4 OF 4

Ordering Information

Example Part Number: 1400LAW1D9-25-D

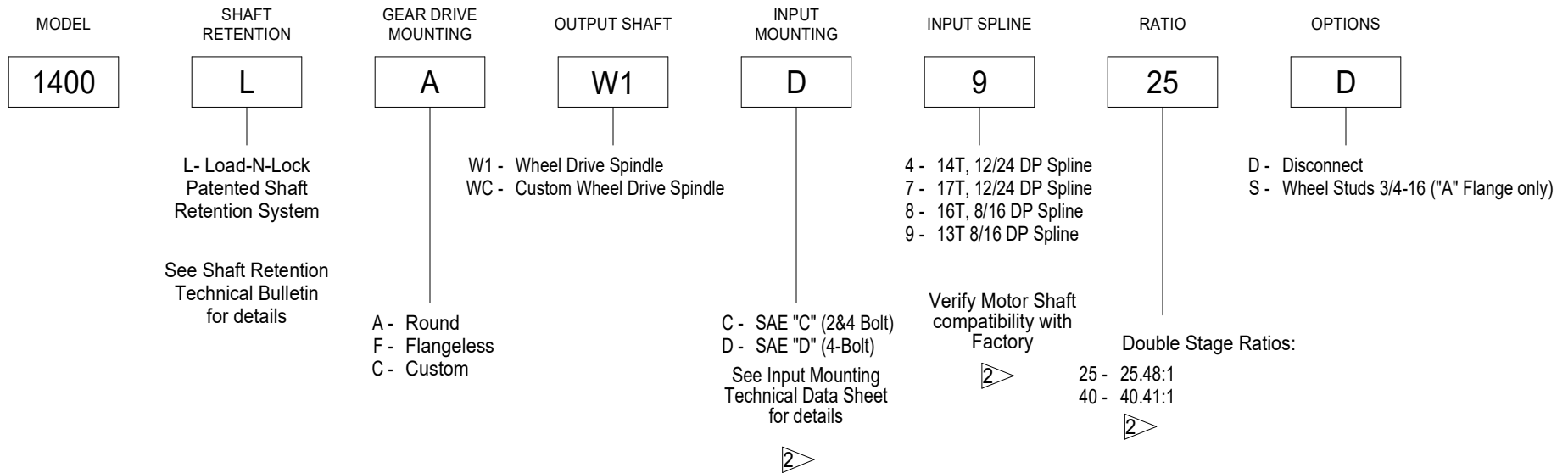

NOTES: ▷

1. TWO STAGE RATIO GEAR BOX SHOWN IN EXAMPLE.
2. THREE STAGE INPUT MOUNTING, INPUT SPLINE AND RATIOS ARE SHOWN ON PAGE 2.