



SERVICE MANUAL DH250 SERIES DIGGER MODELS



Example Part Number

250	334	8	5	F	123	BP	-
Model	Ratio	Shaft	Bail Boss	Motor Supplier	Motor Number	Back Spin Protection	-

THIS SERVICE MANUAL IS EFFECTIVE:
S/N: 158082 TO CURRENT
DATE: 6-2017 TO CURRENT
VERSION: SMD250334-85FXXXBP_BC

NOTE: Individual customer specifications (spindle mounting, sprocket pilot, brake assembly, etc.) may vary from exploded drawing and standard part numbers shown. If applicable, refer to customer drawing for details.

INSTALLATION INFORMATION

The DH250 drive head is designed for anchor setting and digger applications. This drive head uses a high efficiency, solenoid actuated, two speed axial piston motor of optimum performance. The drive head includes an energy protection system that truncates pressure spikes and controls gearbox back driving generated from an anchors torsional energy. These drives require a customer supplied mounting apparatus for connection to the customers mechanized equipment.

The maximum allowable motor pressure is 5000 psi and the maximum flow is 150 GPM in low speed and 105 GPM in high speed. Refer to chart below for more performance information.

The motor will requires a case drain. Fill motor with hydraulic oil to the bottom of the case drain, For two speed operation the electrohydraulic switch requires a 24V excitation voltage. The voltage shifts the motor from 217cc maximum displacement to 115cc minimum displacement. The motor is fixed at maximum displacement if an electrical signal is not applied. Refer to drawing below for motor electrical and hydraulic locations.

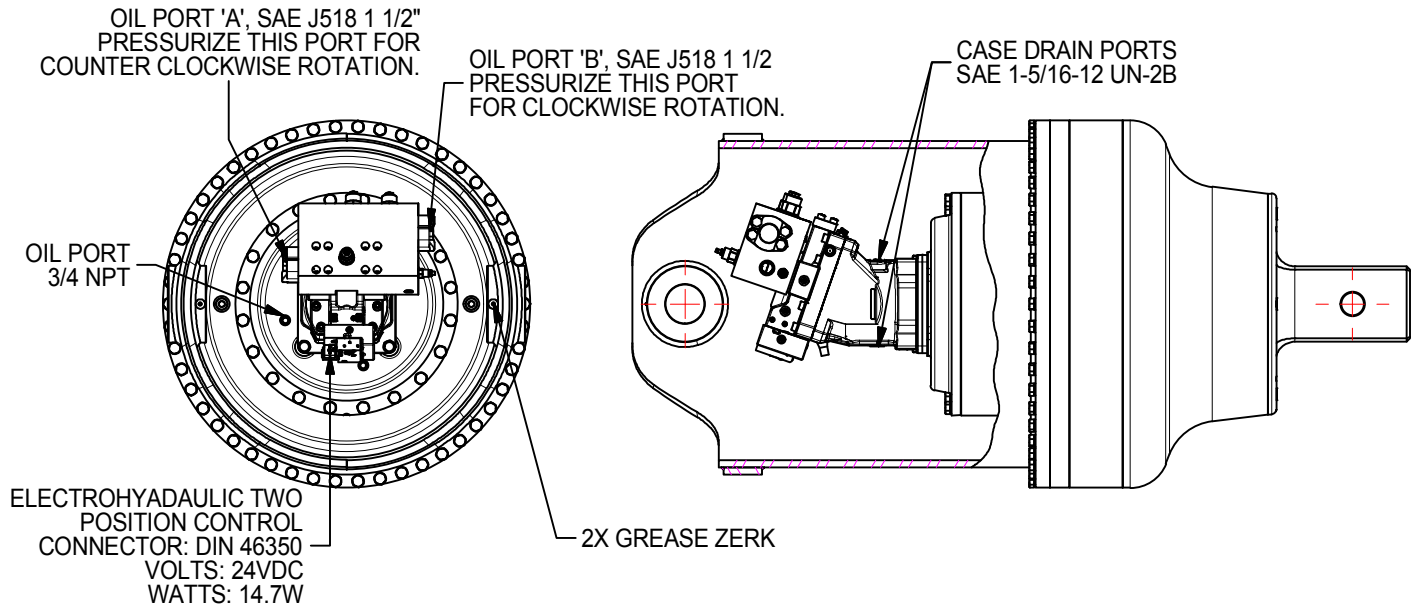

NOTES:

1. BEFORE OPERATION MOTOR MUST BE FILLED WITH HYDRAULIC OIL TO CASE DRAIN.
2. CASE DRAIN REQUIRED.
3. SOLENOID CHANGES MOTOR DISPLACEMENT UNDER LOAD.
 - SOLENOID OFF = MAX DISPLACEMENT
 - SOLENOID ON = MIN DISPLACEMENT

LUBRICATION & MAINTENANCE

GEARBOX OIL REQUIREMENTS

Use the chart below to determine an appropriate lubricant viscosity. Use only EP (extreme pressure) or API GL-5 designated lubricants. The lubricants pour point needs to be 10F below the minimum ambient temperature. Change the lubricant after the first 50 hours of operation and at 500 hour intervals thereafter. The drive should be partially disassembled to inspect gears and bearings at 1000 hour intervals.

Recommended ambient and operating temperatures for conventional and synthetic gear lubricants

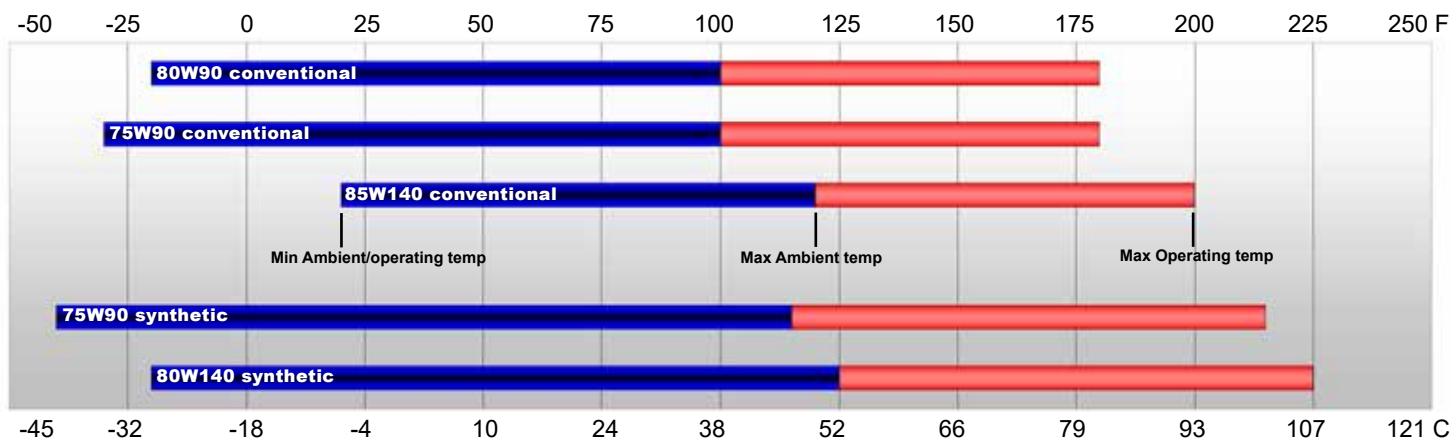

Note: Ambient temperature is the air temperature measured in the immediate vicinity of the gearbox. A gearbox exposed to the direct rays of the sun or other radiant heat sources will operate at higher temperatures and therefore must be given special consideration. The max operating temp must not be exceeded under any circumstances, regardless of ambient temperature.

<u>Operating Position</u>	<u>Oil Capacity</u>	<u>Oil Level</u>
Vertical Shaft (Shaft Down)	28.4 gal	To midway on upper/primary gear set

HYDRAULIC MOTOR OIL REQUIREMENTS

The maximum motor service life is obtained by using a fluid that meets or exceeds ISO cleanliness specifications code 18/13 (ISO 4406). A recommended motor filtration of 10um (absolute) is recommended. Hydraulic main circuit oil temperatures should not exceed 176°F/80°C and drain fluid should not exceed 212°F/100°C. Hydraulic fluid type HLP (DIN 51524), automatic transmission fluids type A, or API CD engine oils can be used. When hydraulic system has reached full operating temperature the minimum oil viscosity from the motor drain should be above 8 mm²/s (cSt). At motor startup the hydraulic fluid viscosity should not exceed 1500 mm²/s (cSt). The ideal operating range for the hydraulic fluid viscosity is 15 to 30 mm²/s (cSt).

PARTS LIST				
GROUP	ITEM	QTY	PART NUMBER	DESCRIPTION
	1	1	45-004-3001	BASE
	2	1	45-004-4001	SHAFT
3	-	-	-	COVERS
	3A	1	45-004-2001	COVER
	3B	1	60-004-1564	COVER-SAE 'E' 600/1000
	4	1	60-004-1552	INPUT GEAR 600/1000 (7.78:1) (15T 8/16)
5	-	-	-	CARRIER ASSEMBLY
	5A	1	45-004-1010	CARRIER - 4500 - 4.42:1
	5B	4	45-004-1003	PLANET GEAR
	5C	4	45-004-1004	PLANET SHAFT
	5D	8	01-110-0130	SPHERICAL ROLLER BEARING
	5E	8	45-004-1008	THRUST WASHER
	5F	4	01-153-0242	ROLL PIN
	5J	4	01-180-0828	RETAINING RING
	5L	1	45-004-1005	PLATE - 4500 SEC CARRIER
	6	1	60-004-1362	SUN GEAR
7	-	-	-	CARRIER ASSEMBLY
	7A	1	60-004-1044	CARRIER SEC
	7B	3	60-004-1232	PLANET GEAR SEC
	7C	3	60-004-1262	PLANET SHAFT - SEC. 600/1400
	7D	6	01-102-0210	TAPERED BEARING CONE
	7E	6	60-004-1291	WASHER - SEC. PLANET 600 1000 1400
	7F	3	01-153-0150	ROLL PIN 1/4" X 1-3/8"
	7G	6	01-103-0210	TAPERED BEARING CUP
	7H	6	60-004-1321	SHIM-SECONDARY PLANET
	7J	6	01-180-0500	RETAINING RING
	7K	3	01-180-0490	RETAINING RING; EXTERNAL; 5100-262
	7L	1	60-004-1352	SECONDARY CARRIER RETAINER
	8	1	45-004-1002	SUN GEAR
9	-	-	-	CARRIER ASSEMBLY
	9A	1	60-004-1722	CARRIER - PRI
	9B	3	60-004-1960	CLUSTER GEAR- LOOSE ROLLER
	9C	3	60-004-1272	PLANET SHAFT - PRI
	9D	84	01-106-0050	ROLLER
	9E	6	60-004-1881	WASHER-PRI PLANET
	9F	3	01-153-0150	ROLL PIN 1/4" X 1-3/8"
	9H	3	01-180-0750	RETAINING RING; INTERNAL; 5008-187
	9M	12	60-004-1891	SPACER WASHER (1400 PRI)
12	-	-	-	RING GEARS
	12A	1	60-004-1213	RING GEAR - COMPOUND PRI
	12B	1	60-004-1253	RING SPACER - CMPD PRI - 600/1000
	12C	1	60-004-1243	RING GEAR - SEC- 1000
	12D	1	45-004-1001	RING GEAR
14	-	-	-	THRUST WASHERS & BEARINGS
	14A	1	01-112-0060	THRUST WASHER
	14L	1	01-112-0340	THRUST BRG
	14G	2	01-112-0350	THRUST RACE
16	-	-	-	SEAL KIT
	16A	1	01-405-0838	SEAL
	16B	4	01-402-0660	O-RING
	16C	2	01-402-1015	O-RING 34.5 ID
20	-	-	-	OUTPUT SHAFT BEARINGS
	20A	2	01-102-0315	BEARING CONE
	20B	2	01-103-0315	BEARING CUP
25	-	-	-	HARDWARE
	25A	70	01-150-1580	HHCS (3/4-10 x 10.5 GRD 8)
	25B	9	01-150-1590	FLAT HD SOC C.S.,GR8 3/8-24X1
	25C	8	01-150-2077	SOCKET HEAD CAP SCREW
	25D	8	01-150-0030	SHCS-1/2-13 X 1-1/4 GR. 8
	25E	4	01-150-1890	HHCS (3/4-10 UNC 1.75" GR5)
	25F	12	01-150-0570	SOC HD CAP SCREW
	25G	1	01-150-2071	SHCS-1/2-13 X 1-1/4 GR. 8
	25H	70	01-186-0350	HARDWASHER - 3/4; 1.25 O.D.
	25J	4	01-186-0360	LOCKWASHER 3/4" MED.
30	-	-	-	PLUGS AND FITTINGS
	30A	2	01-207-0100	PIPE PLUG 3/4 NPT MAGNETIC
	30B	6	01-208-0030	HOLLOW HEX PLUG (05HP-12)
	30F	2	01-215-0050	GREASE FITTING
35	-	-	-	MISCELLANEOUS
	35A	*	45-004-1007	SHIM
	35B	1	45-004-1012	SPLIT RING - 4500
	35C	1	45-004-1011	LOCKING RING
	35D	1	45-004-1000	SEAL CARRIER
	35E	1	01-180-0510	RETAINING RING; INTERNAL
	35F	2	01-201-0778	SPLIT FLANGE KIT
	35G	2	01-201-0779	SPLIT FLANGE PLUG
	35H	1	01-308-0220	ANTI SPIN BACK MANIFOLD
	37	1	45-005-2011	BAIL ASSEMBLY
	50	1	01-304-1220	MOTOR

*QUANTITY DEPENDANT UPON DESIRED BEARING PRELOAD
 X250334-85F122BP ECN: - REV: A 10-01-18 HWP

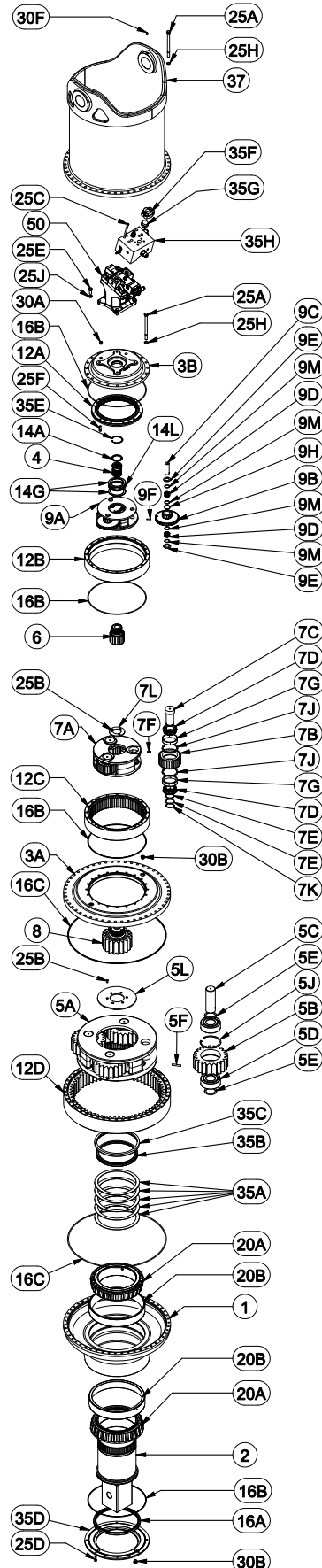

Unit Disassembly Procedure

- 1) Scribe a diagonal line across the outside of the unit from the bail (37) to the base (1) before disassembly to aid in the proper positioning of pieces during reassembly.
- 2) Remove magnetic drain plugs (30B) and drain oil from unit. The oil will drain out faster and more completely if warm.
- 3) Remove the fifty hex-head capscrews (25A) and flat washers (25H).
- 4) Separate bail (37) from gearbox and remove from digger assembly.
- 5) Install two hex-head capscrews (25A) into cover (3A) to retain gearbox assembly together while disassembling motor, Stage I and Stage II assemblies.
- 6) Remove motor (50) from cover (3B) by removing four hex-head fasteners (25E) and flat washers (25J).
- 7) Remove 20 3/4-10 capscrews (25A) and flat washers (25H). Remove cover (3B), thrust bearings (14A, 14G & 14L), and input gear (4). Inspect o-ring (16B); discard if damaged or deformed.
- 8) Lift Stage I planetary carrier assembly (9) out of the unit. Remove ring gear spacer (12B) and inspect o-ring (16B); discard if damaged or deformed.
- 9) Remove Stage II sun gear (6) from secondary carrier assembly (7).
- 10) Remove the three 3/8-24 flat head capscrews (25B) securing the carrier retaining plate (7L) to the Stage III sun gear (8).
- 11) Remove Stage II ring gear (12C) and Stage II carrier assembly (7). Inspect o-ring (16B), discard and replace any damaged or deformed o-rings.
- 12) Remove two hex-head capscrews (25A) from cover (3A). Lift cover from gearbox. Inspect o-ring (16C), discard and replace any damaged or deformed o-rings.
- 13) Remove Stage III sun gear (6) from Stage III carrier assembly.
- 14) Remove the six 3/8-24 flat head capscrews (25F) securing the carrier retaining plate (5L) from output shaft (2).
- 15) Remove Stage III ring gear (12D) and Stage III carrier assembly (5). Inspect o-ring (16C), discard and replace any damaged or deformed o-rings.
- 16) The unit is now separated into subassemblies. The area(s) requiring repair should be identified by thorough inspection of the individual components after they have been cleaned and dried.

Stage I Carrier Subassembly

(Items 9A, 9B, 9C, 9D, 9E, 9F, 9H & 9M)

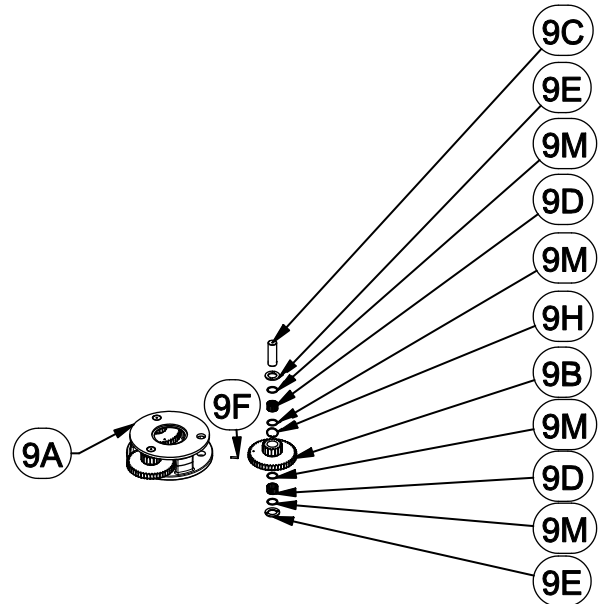

Disassembly

- 1) Rotate planet gears (9B) to check for abnormal noise or roughness in bearings (9D) or planet shafts (9C). If further inspection or replacement is required, proceed as follows.
- 2) Drive roll pins (9F) completely into the planet shafts (9C).
- 3) Press or drive planet shafts (9C) out of carrier (9A).
- 4) Remove planet gears (9B) and thrust washers (9E & 9M) and bearings (9D) from the carrier (9A).
- 5) Inspect the planet gear (9B) bearing bore, planet shaft (9C) and rollers (9D). Check for spalling, bruising or other damage. Replace components as necessary; rollers should be replaced as a set of 56. Replace any parts where abnormal wear is found.
- 6) Use 3/16 inch pin punch to remove roll pins (9F) from planet shafts (9C).

NOTE: If either the rollers or the planet shafts (pins) are damaged, both components should be replaced.

Reassembly

- 1) Rebuild primary planet carrier assembly in reverse order using any needed new parts.
- 2) Install rollers in gear as follows:
 - a) Set planet gear (9B) onto table. Install one roller spacer (9M) into planet gear bore and seat on internal retaining ring (9H).
 - b) Center the planet shaft (9C) in the planet gear (9B) bearing bore.
 - c) Begin placing rollers (9D) around the shaft (9C). There should be clearance for the last roller to slide in. Be sure to install 28 rollers in each planet gear.

- d) Place spacer washer (9M) onto planet rollers.
 - e) Place thrust washer (9E) onto planet gear (9B) remove planet shaft.
 - f) Carefully slide the assembly off the table and rotate 180 degrees placing thrust washer onto table. Repeat steps 1 (a-e).
 - g) Align the planet gear/bearing assembly inside the carrier and install the planet shaft through the entire assembly.
- 3) Planet shaft (9C) should be installed with the chamfered end of the 3/16 inch hole towards the outside diameter of the carrier (9A); this will aid in alignment of holes while inserting roll pins (9F).
 - 4) Drive roll pin (9F) into the carrier hole and into the planet shaft to retain the parts. Repeat for remaining planet gears

Stage II Carrier Subassembly

(Items 7A, 7B, 7C, 7D, 7E, 7F, 7G, 7J 7K, 7L & 25B)

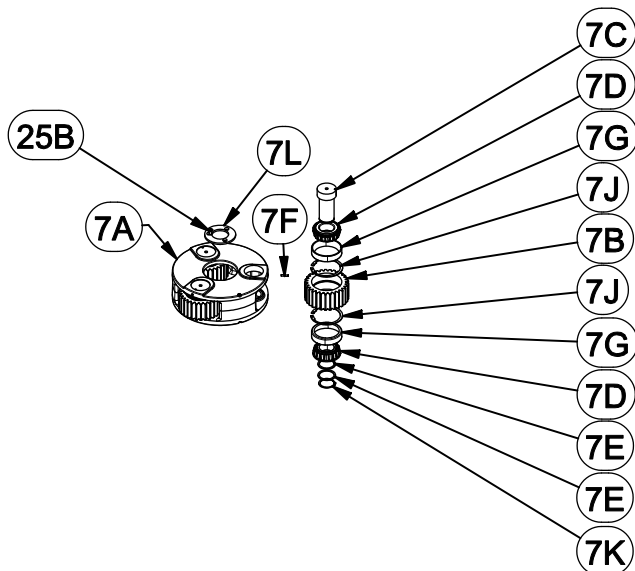

Disassembly

- 1) Rotate planet gears (7B) to check for abnormal noise or roughness in bearings (7D & 7G). If further inspection or replacement is required, proceed as follows.
- 2) Removing retaining ring (7K), washer (7E) and shims from planet shaft (7C).
- 3) Press planet shafts (7C) out of carrier (7A).
- 4) Remove planet gears (7B) and washer (7E) from carrier.
- 5) Inspect the planet gear (7B), bearing cone (7D), bearing cup (7G) and planet shaft (7C). Check for spalling, bruising or other damage. Replace components as necessary; bearing need to be replaced as a cup and cone set.
- 6) Replace any parts where abnormal wear is found.

Reassembly

- 1) Rebuild Stage II planet carrier assembly in reverse order using any needed new parts.
- 2) Install bearing cones (7D) into planet gear bearing cups (7G). Place washer (7E) onto interior carrier spot faced surface.
- 3) Place carrier retainer (7L) into carrier (7A). Insert planet gear assembly into carrier (7A). Slide planet shaft (7C) into carrier and align planet pin notch with roll pin in carrier.
- 4) Place shims and washer (7E) onto planet shaft. Install retaining ring (7K). Rotate planet gears by hand to test bearing preload. Correct bearing preload on the planet gears requires 50-75 in-lbs rotating torque. If gear doesn't rotate remove a shim and test again until a smooth loaded rotation is developed. Repeat for remaining planet gears.

Stage III Carrier Subassembly

(Items 5A, 5B, 5C, 5D, 5E, 5F, 5J & 5L)

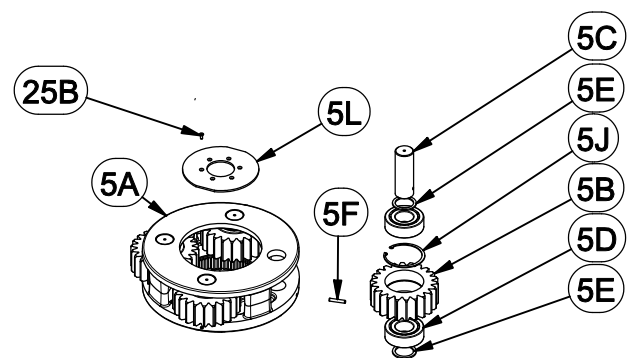

Disassembly

- 1) Rotate planet gears (5B) to check for abnormal noise or roughness in bearings (5D). If further inspection or replacement is required, proceed as follows.
- 2) Drive roll pins (5F) completely into the planet shafts (5C).
- 3) Press or drive planet shafts (5C) out of carrier (5A).
- 4) Remove planet gears (5B) and spacers (5E) from the carrier (5A).
- 5) Inspect the planet gear (5B) and planet bearings (5D) for spalling, bruising or other damage.
- 6) Replace any parts where abnormal wear is found.
- 7) Use 1/4 inch pin punch to remove roll pins (5F) from planet shafts (5C).

Reassembly

- 1) Install carrier retainer (5L) into carrier (5A). Place planet spacers (5E) onto planet bearings (5D) and install assembly into carrier (5A).
- 2) Planet shafts (5C) should be installed with chamfered end

of 1/4 inch hole toward outside diameter of the carrier (5A). This will aid in alignment of holes while inserting roll pins (5F).

- 3) Drive a roll pin (5F) through the carrier hole and into the planet shaft to retain the parts. Repeat for other planet gears.

Base Subassembly

(Items 1, 2, 16A, 16B, 20A, 20B, 25D, 30B, 35A, 35B, 35C & 35D)

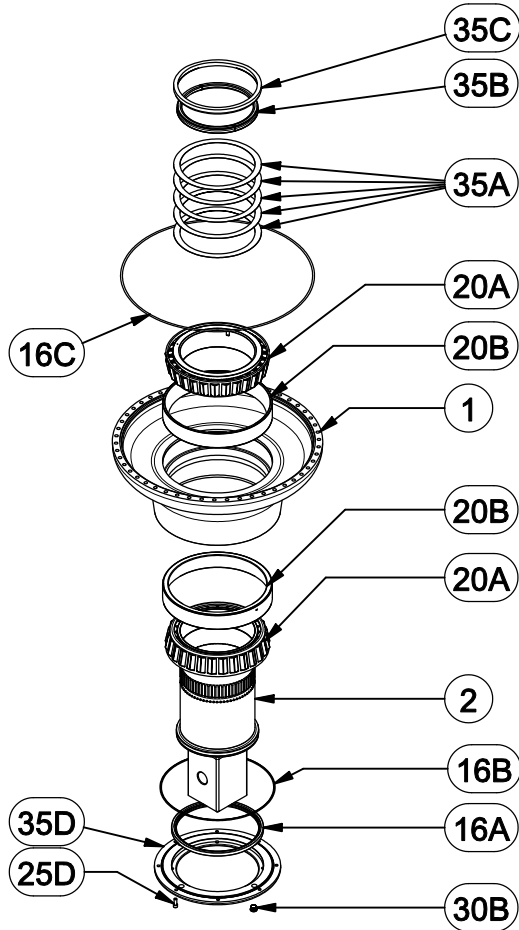

Disassembly

- 1) Remove the seal carrier retaining screws (25D) and seal carrier (35D) from unit. Inspect seal (16A) and o-ring (16B) for signs of wear or damage and replace as necessary.
- 2) Remove the lock ring (35B) using a heel bar or puller; if using a heel bar, be sure not to pry against the cage of the inner output shaft bearing (20A). Remove the split ring segments (35B) and shims (35A).

Caution: Since the output shaft is no longer retained, care should be taken to avoid personal injury. Care should also be taken not to damage the shaft when pressing through base.

- 3) Base (1) should be set with output shaft side down, as shown, on a plate or table. Press output shaft through the bottom of base by applying a load to top end (internal end) of shaft until it passes through inner shaft bearing cone (20A).

- 4) A gear puller may be used to remove the outer bearing cone (20A) from the shaft (2). If reusing old bearing cone, do not pull on or damage roller cage.

- 5) Inspect inner and outer bearing cups (20A & 20B). If cups are damaged, drive them out using a brass drift

Reassembly

- 1) Place base (1) (output side up, opposite shown) on the table.
- 2) Apply a layer of lithium or general purpose bearing grease to the roller contact surface of outer bearing cup (20B).
- 3) Press outer bearing cone (20A) (large end down as shown) onto the shaft until it seats against the shoulder.

Note: Press bearing cone onto output shaft by pressing on inner race only. DO NOT press on roller cage, as it may damage bearing.

- 4) Place the shaft (2) with the bearing (12A) into the base (1).
- 5) Install o-ring (16B) onto seal carrier (35B). Lubricate inner lip of shaft seal (16A) and slide seal carrier assembly onto the shaft (2). Install seal carrier fasteners (25D) and torque to 110 ft-lbs dry and 80 ft-lbs lubed. Flip this assembly, resting the base (1) on the end of the output shaft (2).
- 6) Apply a layer of lithium or general purpose bearing grease to the roller contact surface of the inner cup (20B). Press the inner bearing cone (20A) (large end up as shown) onto the shaft (2) until it is seated against inner bearing cup (20B).
- 7) The shaft bearing preload needs to result in a rolling torque between 300 to 400 in-lb. Adding shims (35A) will increase the pre-load on the bearing set. Install the Load-N-Lock™ segments (35B) over the shims (35A) and into the groove in the shaft (2). When the load and lock assembly is installed properly it will not rotate because it is firmly engaged with the shims. Finally, install the lock ring (35C) over the segments (35B).

All subassembly service or repairs should be complete at this time. Continue to Unit Assembly to complete unit buildup.

Unit Assembly

- 1) When all subassemblies are complete, the unit is ready to be assembled.
- 2) Install the Stage III carrier assembly onto the output shaft; align the splines of the carrier (**5A**) with the splines of the shaft (**2**) and slide the carrier onto the shaft.
- 3) Place removable thread locking compound onto the 3/8-24 flathead capscrews (**25B**). Install capscrews into carrier retaining plate (**5L**) and **torque to 35ft-lbs**.
- 4) Install Stage III sun gear (**8**) into Stage III carrier assembly.
- 5) Lubricate o-ring (**16C**) and install on the pilot of the Stage III ring gear (**12D**). Align gear teeth of ring gear (**12D**) with the gear teeth of the planet gears (**5B**) and place on base. Align mounting holes of ring gear with holes in base. Using the scribed line made during disassembly for reference.
- 6) Lubricate o-ring (**16C**) and install on the pilot of the cover (**3A**). Install cover onto Stage III ring gear (**12D**) and align mounting holes.
- 7) Install Stage II carrier assembly onto the Stage III sun gear (**8**) splines. The carrier retaining plate (**7L**) holes need to be positioned so that all fasteners can be installed. Place removable thread locking compound onto the 3/8-24 flathead capscrews (**25B**). Install capscrews into carrier retaining plate (**7L**) and **torque to 35ft-lbs**.
- 8) Lubricate o-ring (**16B**) and install on the pilot of the Stage II ring gear (**12C**). Align gear teeth of ring gear (**12C**) with the gear teeth of the planet gears (**7B**) and place on cover (**3A**). Align mounting holes of ring gear with holes in base.
- 9) Install Stage II sun gear (**6**) into Stage II carrier assembly (**7**).
- 10) Lubricate o-ring (**16B**) and install on the pilot of the Stage I ring gear spacer (**12B**) then install spacer.
- 11) Place Stage I carrier assembly (**9**) onto Stage II sun gear (**6**).
- 12) Compound primary timing instructions:
 - a) The planet gears will now need to be timed. Refer to the diagram. The planet gears each have a timing mark, usually a round punch locate timing marks on planet gear (**9B**).
 - b) As seen from above, start with the top planet gear and position it's timing mark pointing straight down. Next, rotate the lower left planet gear counterclockwise as indicated in the timing diagram. Then rotate the lower right planet gear clockwise as indicated.
 - c) Set the input gear (**4**) and the input thrust race (**14A**) into the center of the primary planet carrier assembly.
 - d) If compound primary ring gear (**12A**) was not removed during disassembly, then skip to step 13. Otherwise, bolt to the inside of the cover (**3A**) with twelve bolts (**25D**). Use a removable thread locking compound on the threads of the bolts. **Tighten to 110 ft.-lbs. dry or 80 ft.-lbs. lubricated.**

TIMING DIAGRAMS

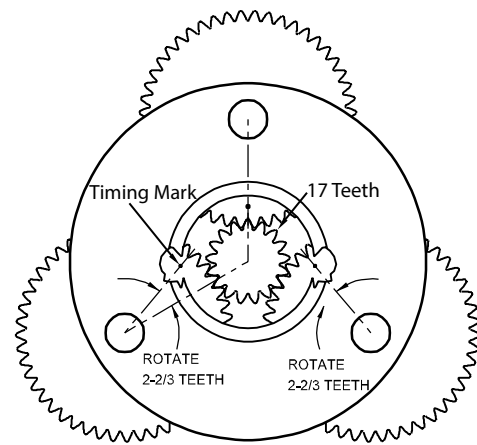

- 13) Install thrust washer (**14G**) onto Stage I carrier then install thrust bearing (**14L**) and thrust washer (**14G**).
- 14) Lubricate o-ring (**16B**) and install on the pilot of the cover (**3A**).
- 15) Noting the scribed line made during disassembly, install the cover (**3B**). Install 2 fasteners (**25A**) into Stage III ring gear and 2 fasteners (**25A**) into Stage II and Stage I to constrain unit while spin testing.
- 16) Ensure the unit spins freely by using a splined shaft to drive the input gear (**4**). If unit does not rotate freely for one complete output shaft revolution remove cover and verify Stage I planet gearing is timed correctly.
- 17) Finish installing 20 3/4-10 hex head capscrews (**25A**) with flat washers (**25H**) into the Stage II and Stage I assembly. **Torque the capscrews to 380 ft-lbs dry, 280 ft-lbs lubricated.**
- 18) Install motor (**50**) onto cover (**3B**). Install 4 3/4-10 fasteners (**25E**) and washers (**25J**). **Torque fasteners to 380 ft-lb dry 280 ft-lbs when lubricated.**
- 18) Remove temporarily fasteners installed in cover (**3A**). Place bail (**37**) onto assembly and aligning holes in bail and cover using scribed line made during disassembly as a reference. Install 50 3/4-10 hex head capscrews (**25A**) with flat washers (**25H**). **Torque the capscrews to 380 ft-lbs dry, 280 ft-lbs lubricated.**
- 19) Fill the unit to the proper level, as specified, with GL5 EP oil.

The digger is now ready to use.