



520 GEAR DRIVE - SHAFT OUTPUT

520,000 in-lb (58,800 N-m) Intermittent Rating 260,000 in-lb (29,400 N-m) Continuous Rating

Typical Applications: Industrial, Marine or Mobile Equipment

(913) 782-1238 (Tel)
 (913) 782-4206 (Fax)
 Sales@Eskridgeinc.com
 www.Eskridgeinc.com
 FORM: PS444L-AD

520 2-Stage General Dimensions Flanged 'A' Option

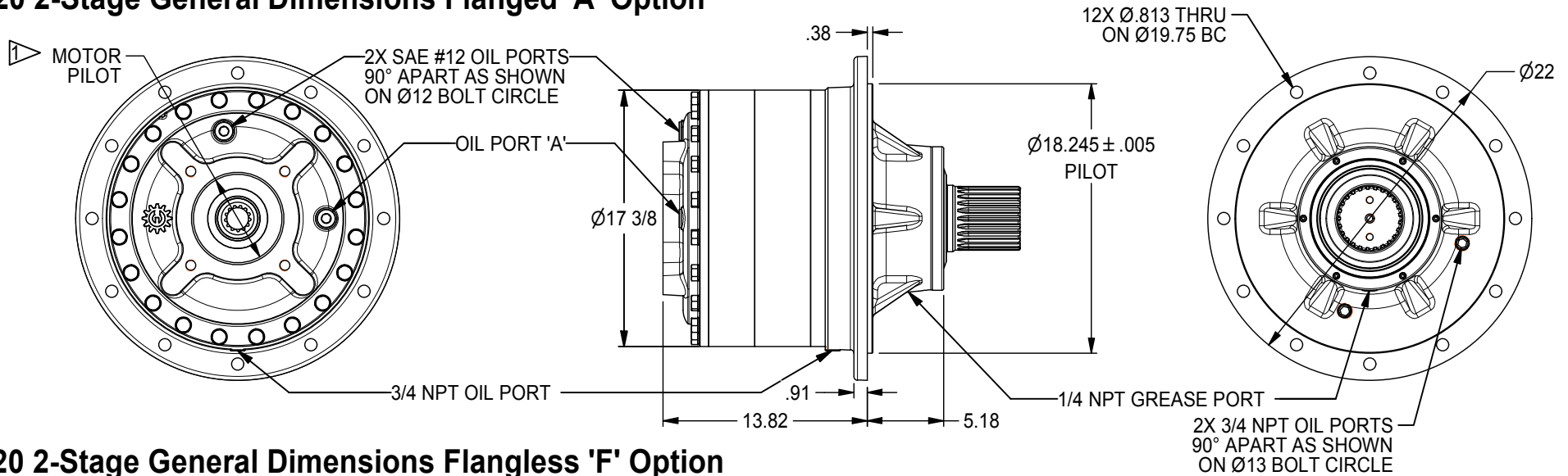

520 2-Stage General Dimensions Flangless 'F' Option

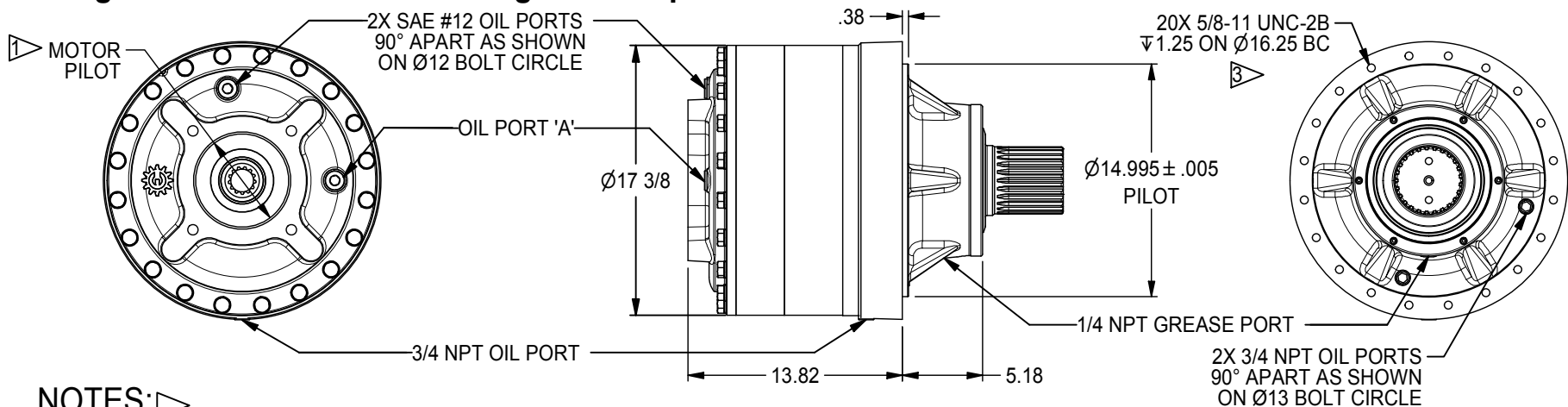

NOTES: ▷

1. SPECIFICATIONS CALLED OUT IN MOTOR MOUNT DIMENSIONS SECTION.
2. VALUES ARE SHOWN IN INCHES.
3. 'T' OPTION; THROUGH BOLT MOUNTING, HOLES ARE 18X Ø.656 HOLE ON Ø16.25 B.C.
4. OUTPUT SHAFT ROTATION SAME AS INPUT ROTATION.

ORIENTATION	HORIZONTAL:	VERTICAL: PINION DOWN	VERTICAL: PINION UP
LUBRICATION			
QUANTITY	7.50 Qt	10.50 Qt	10.50 Qt
OIL FILL LEVEL (GRADE GL-5 EP 80/90)	FILL TO: 1/2 TO 2/3 FULL	FILL TO: 1.5" FROM COVER PORT "A"	FILL TO: PORT "B"



520 GEAR DRIVE - SHAFT OUTPUT

520,000 in-lb (58,800 N-m) Intermittent Rating 260,000 in-lb (29,400 N-m) Continuous Rating

Typical Applications: Industrial, Marine or Mobile Equipment

(913) 782-1238 (Tel)
 (913) 782-4206 (Fax)
 Sales@Eskridgeinc.com
 www.Eskridgeinc.com
 FORM: PS444L-AD

3-Stage Option M-28 First Stage (Base Dimensions Identical to 2-Stage Option)

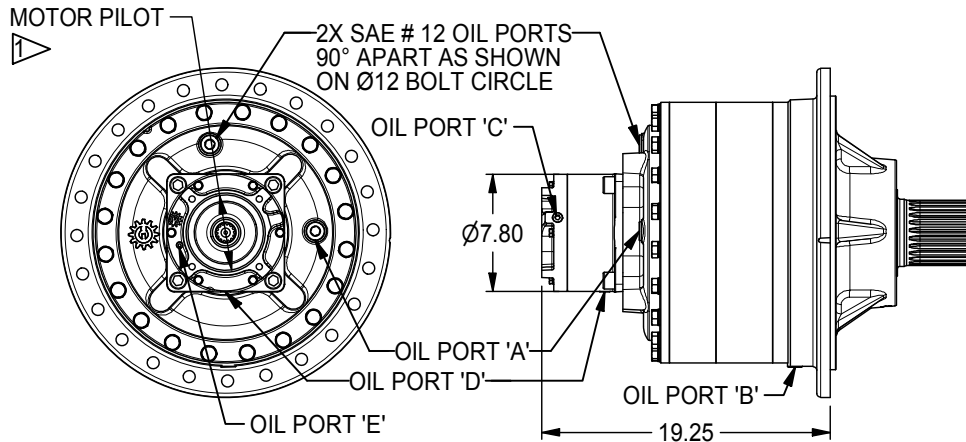

Available Ratios:

73	(73.31:1)
80	(79.76:1)
*99	(98.77:1)
109	(109.01:1)
119	(118.60:1)
141	(140.92:1)
*147	(146.87:1)
153	(153.33:1)
*190	(187.88:1)

Input Mounting:

SAE "A" (2 & Modified 4 Bolt)
SAE "B" (2 & 4 Bolt)
SAE "C" (2 & 4 Bolt)

Input Spline:

2 (13T 16/32 DP Spline)
3 (1"-6B SAE Parallel Sided Spline)
4 (14T 12/24 DP Spline)
5 (15T 16/32 DP Spline)

*3-Stage Option with Code 4 Input for 99:1; 147:1 & 190:1 Ratios

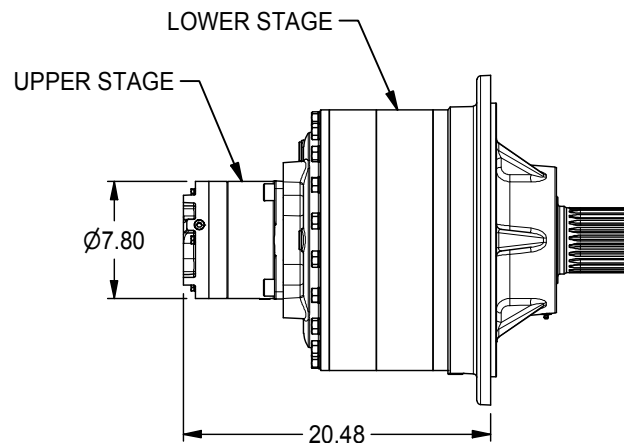

Oil Volume (3 Stage With M28) Upper Stage

LUBRICATION	ORIENTATION	HORIZONTAL:	VERTICAL: PINION DOWN	VERTICAL: PINION UP
QUANTITY		1.0 Pt/1.25 (Code 4)	1.8 Pt/1.25 (Code 4)	1.8 Pt/2.25 (Code 4)
OIL FILL LEVEL (GRADE GL-5 EP 80/90)		FILL TO: PORT 'C'	FILL TO: 1.5" FROM COVER PORT 'E'	FILL TO: PORT 'D'

Oil Volume Lower Stage

LUBRICATION	ORIENTATION	HORIZONTAL:	VERTICAL: PINION DOWN	VERTICAL: PINION UP
QUANTITY		7.50 Qt	10.50 Qt	10.50 Qt
OIL FILL LEVEL (GRADE GL-5 EP 80/90)		FILL TO: PORT 'A'	FILL TO: 1.5" FROM COVER PORT 'A'	FILL TO: PORT 'B'

All Units Shipped Without Oil

NOTES:

- SPECIFICATIONS CALLED OUT IN MOTOR MOUNT DIMENSIONS SECTION.
- UPPER AND LOWER STAGES SEPARATED WITH A SEAL. BOTH STAGES NEED TO BE FILLED WITH OIL.



520 GEAR DRIVE - SHAFT OUTPUT

520,000 in-lb (58,800 N-m) Intermittent Rating 260,000 in-lb (29,400 N-m) Continuous Rating
 Typical Applications: Industrial, Marine or Mobile Equipment

(913) 782-1238 (Tel)
 (913) 782-4206 (Fax)
 Sales@Eskridgeinc.com
 www.Eskridgeinc.com
 FORM: PS444L-AD

3-Stage Option 254 First Stage (Base dimensions identical to 2-Stage Option)

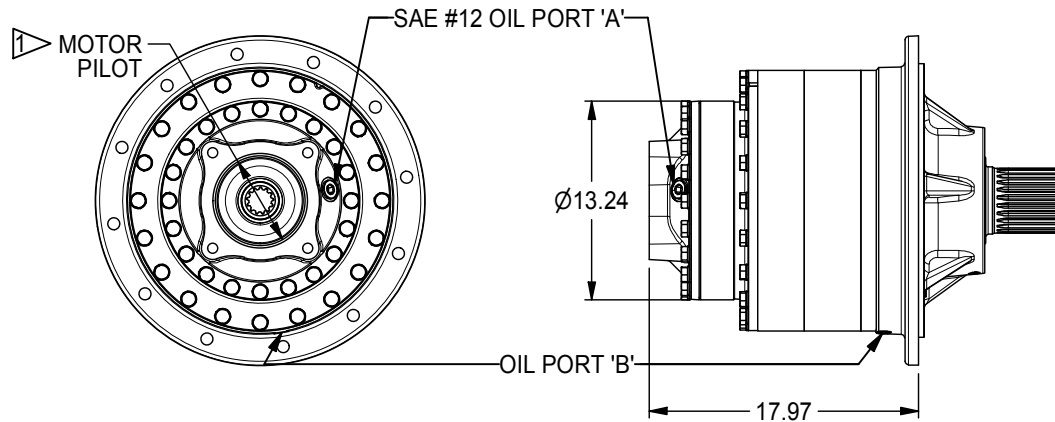

Available Ratios:

- 84 (84.30:1)
- 110 (109.64:1)
- 123 (123.16:1)
- 125 (125.36:1)
- 162 (162.06:1)
- 163 (163.04:1)
- 167 (167.56:1)
- 183 (183.13:1)
- 211 (210.77:1)
- 237 (236.75:1)
- 249 (249.16:1)
- 322 (322.11:1)

Input Mounting:

- SAE "A" (2 & Modified 4 Bolt)
- SAE "B" (2 & 4 Bolt)
- SAE "C" (2 & 4 Bolt)
- SAE "D" (4 Bolt)

Input Spline:

- 4 (14T 12/24 DP Spline)
- 9 (13T 8/16 DP Spline)

Oil Volume (3 Stage With 254)

LUBRICATION	ORIENTATION	HORIZONTAL:	VERTICAL: PINION DOWN	VERTICAL: PINION UP
	QUANTITY		9.00 Qt	15.00 QT
OIL FILL LEVEL (GRADE GL-5 EP 80/90)		FILL TO: PORT 'A'	FILL TO: 1.5" FROM COVER PORT 'A'	FILL TO: PORT 'B'

All Units Shipped Without Oil

NOTES:

1. SPECIFICATIONS CALLED OUT IN MOTOR MOUNT DIMENSIONS SECTION.



520 GEAR DRIVE - SHAFT OUTPUT

520,000 in-lb (58,800 N-m) Intermittent Rating 260,000 in-lb (29,400 N-m) Continuous Rating
Typical Applications: Industrial, Marine or Mobile Equipment

(913) 782-1238 (Tel)
(913) 782-4206 (Fax)
Sales@Eskridgeinc.com
www.Eskridgeinc.com
FORM: PS444L-AD

D1 Output Shaft 25 Tooth 6/12 DP Spline

AVAILABLE OPTIONS:
SPLINED HUB: P/N 42-004-4052
RETAINER KIT: P/N 42-018-0221

See Hubs & Pinions technical
data sheet for details

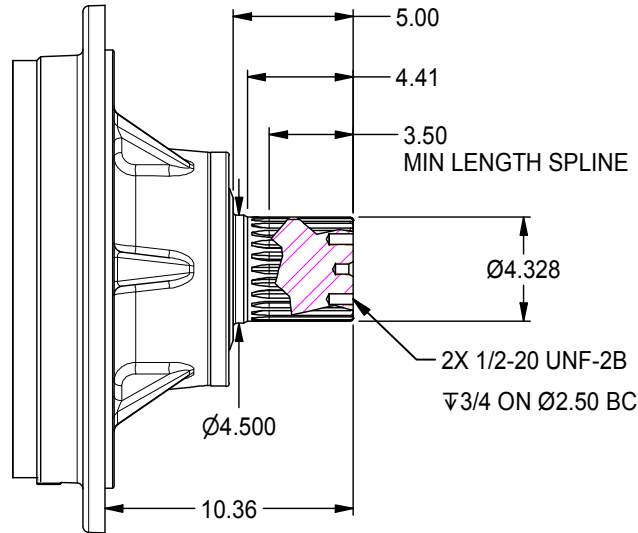

D2 Output Shaft 1.25" Keyway

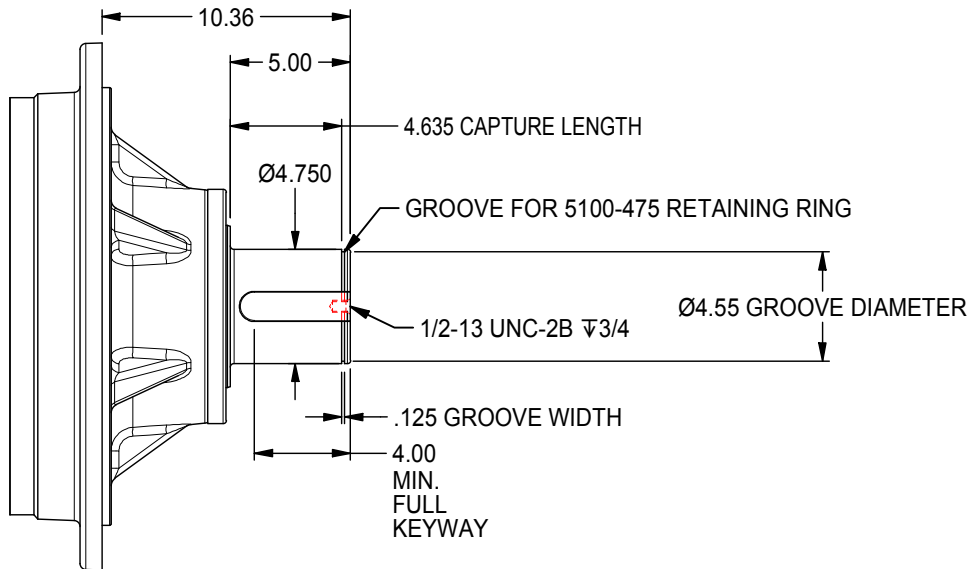



520 GEAR DRIVE - SHAFT OUTPUT

520,000 in-lb (58,800 N-m) Intermittent Rating 260,000 in-lb (29,400 N-m) Continuous Rating
 Typical Applications: Industrial, Marine or Mobile Equipment

(913) 782-1238 (Tel)
 (913) 782-4206 (Fax)
 Sales@Eskridgeinc.com
 www.Eskridgeinc.com
 FORM: PS444L-AD

Performance Ratings

Maximum Intermittent Output Torque: 520,000 in-lb (58,800 N-m)
 Continuous Output Torque: 260,000 in-lb (29,400 N-m)
 Maximum Input Speed: 3,000 RPM
 Maximum Operating Ambient Temperature: 110° F (43° C)
 Minimum Operating Ambient Temperature: -20° F (-28° C)

*Above ratings are general, mechanical ratings, not thermal ratings.
 Continuous duty may require additional cooling.
 Consult your Eskridge representative to determine
 ratings for your specific application or configuration*

Motor Mount Dimensions

PILOT DIMENSIONS	BOLT CIRCLE
*SAE 'A' Ø3.251/3.255	4X 1/2-13 UNC-2B ∇.50 ON Ø4.1875 B.C.
*SAE 'B' Ø4.001/4.005	2X 1/2-13 UNC-2B ∇.50 ON Ø5.750 B.C.
SAE 'C' Ø5.001/5.004	4X 1/2-13 UNC-2B ∇1 ON Ø6.375 B.C. 2X 5/8-11 UNC-2B ∇1 ON Ø7.125 B.C.
SAE 'D' Ø6.000/6.004	4X 3/4-10 UNC-2B ∇1 ON Ø9.000 B.C.
SAE 'E' Ø6.501/6.505	4X 3/4-10 UNC-2B ∇1 ON Ø12.500 B.C.

*SAE 'A' & 'B' ONLY OFFERED ON 3 STAGE GEARBOXES

Approximate Unit Weight

Single Stage: 450 lb (204 kg)
 Two Stage: 700 lb (318 kg)
 Three Stage: 850 lb (386 kg)

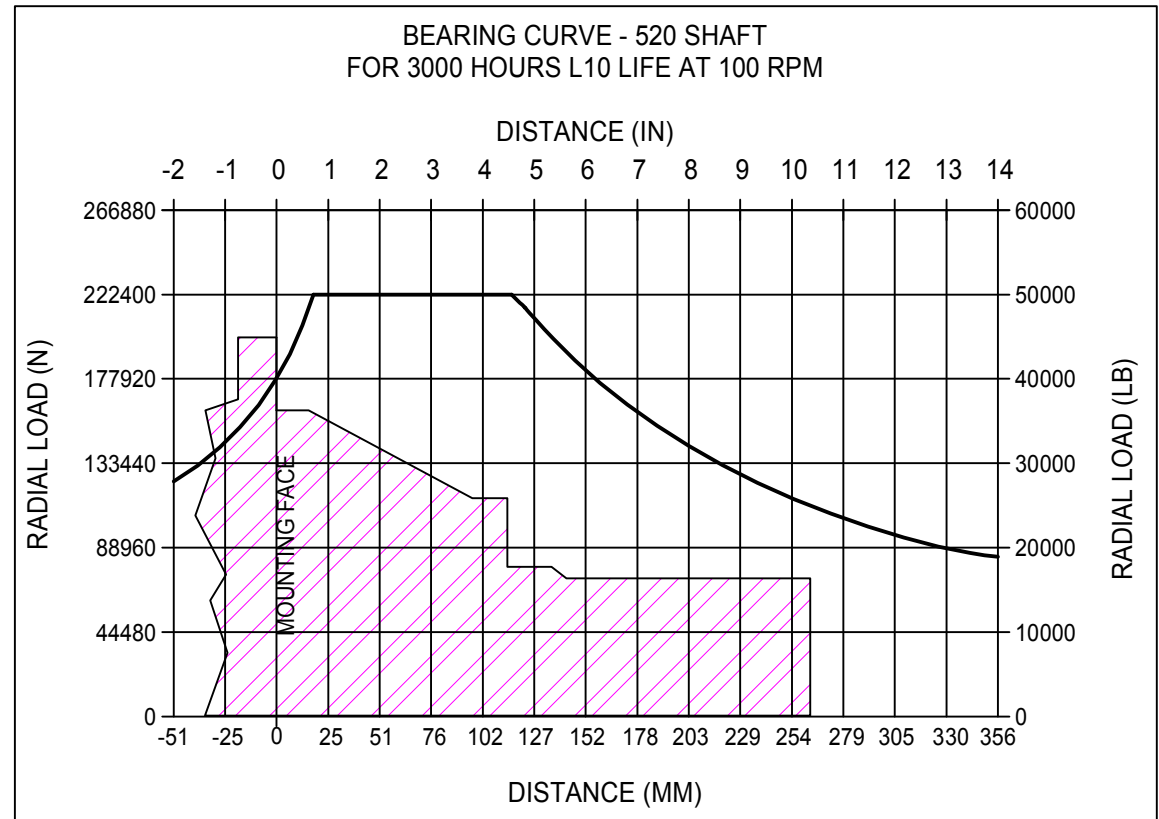

To adjust for loads and speeds other than those shown on above curve, use this formula:

$$\text{Adjusted Life (hours)} = 3000 \left(\frac{100 \text{ rpm}}{\text{Speed (Adjusted)}} \right) \times \left(\frac{\text{Load (Curve)}}{\text{Load (Adjusted)}} \right)^{10/3}$$



520 GEAR DRIVE - SHAFT OUTPUT

520,000 in-lb (58,800 N-m) Intermittent Rating 260,000 in-lb (29,400 N-m) Continuous Rating
Typical Applications: Industrial, Marine or Mobile Equipment

(913) 782-1238 (Tel)
(913) 782-4206 (Fax)
Sales@Eskridgeinc.com
www.Eskridgeinc.com
FORM: PS444L-AD

Ordering Information

Example Part Number: 520LAD1D9-38-Z

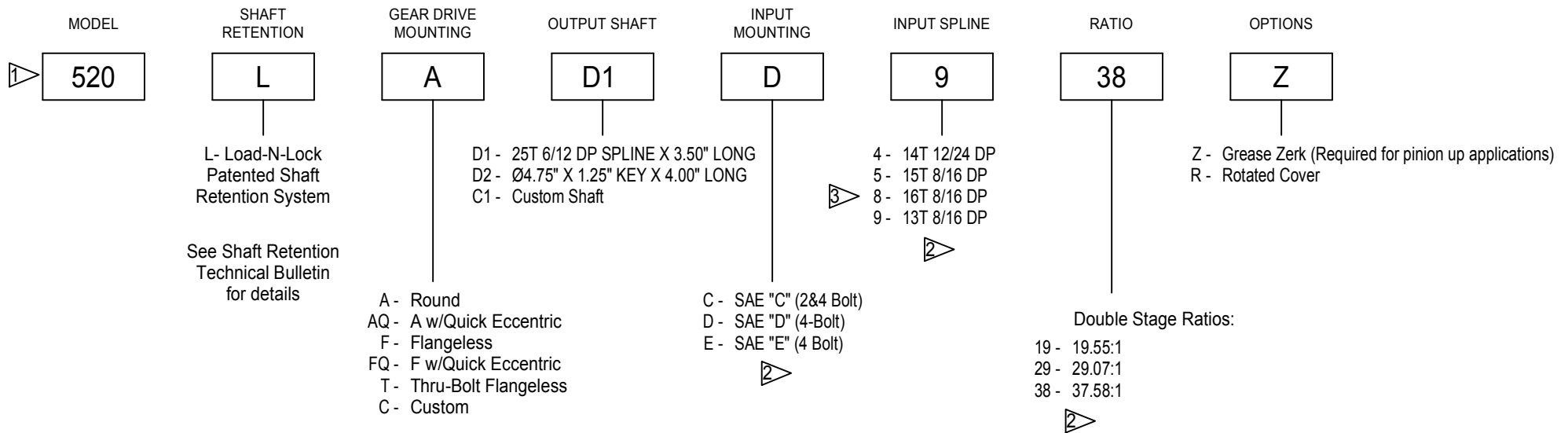

NOTES:

1. TWO STAGE RATIO GEARBOX SHOWN IN EXAMPLE.
2. THREE STAGE INPUT MOUNTING, INPUT SPLINE AND RATIOS ARE SHOWN ON PAGES 2 & 3.
3. 16T ONLY AVAILABLE ON 19:1 & 29:1 TWO STAGE RATIOS.