



312 GEAR DRIVE - SHAFT OUTPUT

310,000 in-lb (35,000 N-m) Intermittent Rating 160,000 in-lb (18,100 N-m) Continuous Rating
 Typical Applications: Industrial, Marine or Mobile Equipment

(913) 782-1238 (Tel)
 (913) 782-4206 (Fax)
 Sales@Eskridgeinc.com
 www.Eskridgeinc.com
 FORM: PS312L-AC
 SHEET 1 OF 5

312 2-Stage General Dimensions Flanged 'A' Option

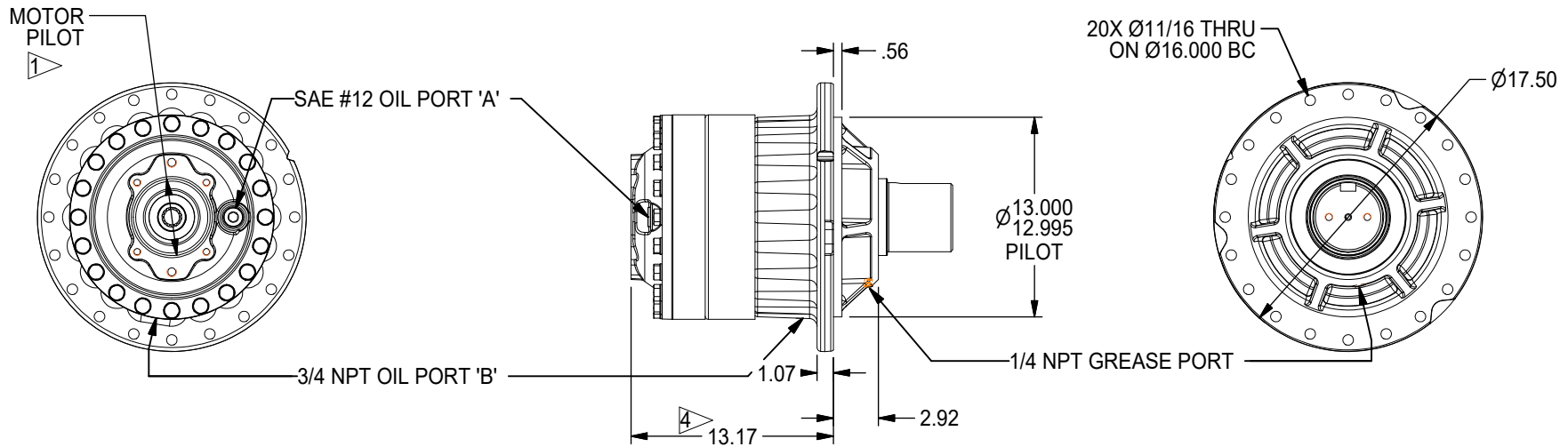

312 2-Stage General Dimensions Flangeless 'F' Option

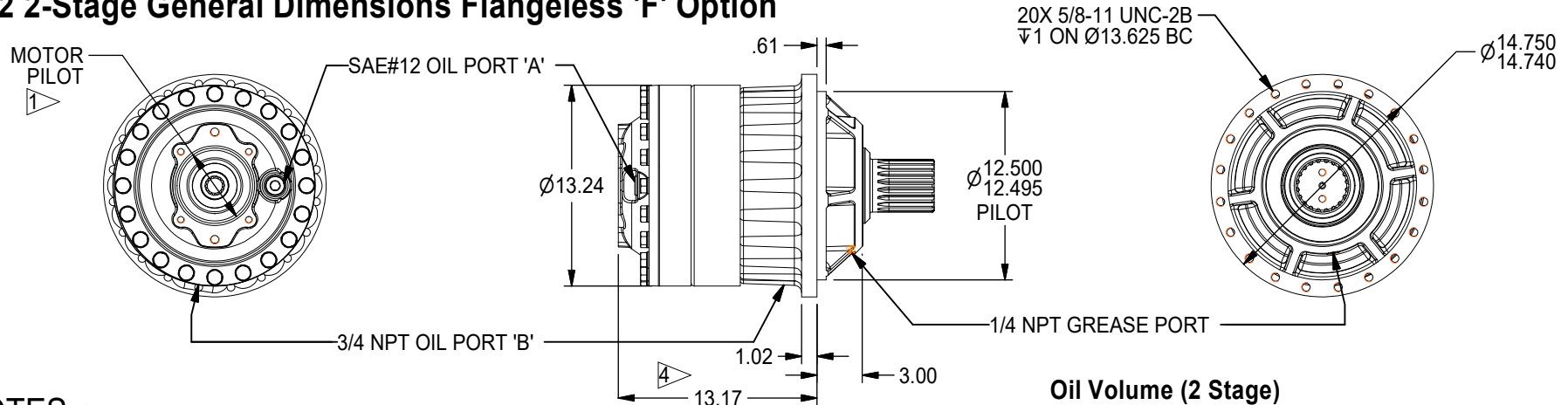

NOTES: ▷

1. SPECIFICATIONS CALLED OUT IN MOTOR MOUNT DIMENSIONS SECTION.
2. VALUES ARE SHOWN IN INCHES.
3. OUTPUT SHAFT ROTATION SAME AS INPUT ROTATION.
4. DIMENSION 13.98 FOR SAE D MOTOR MOUNTS

Oil Volume (2 Stage)

| LUBRICATION | ORIENTATION | HORIZONTAL: | VERTICAL: PINION DOWN | VERTICAL: PINION UP |
|--|-------------|-------------------|--------------------------------------|------------------------|
| QUANTITY | | 6.75 Pt | 12.75 Pt | 12.75 Pt |
| OIL FILL LEVEL (GRADE GL-5 EP 80/90) | | FILL TO: PORT 'A' | FILL TO: 1.5" FROM COVER PORT 'A' | FILL TO: PORT 'B' |

All Units Shipped Without Oil



312 GEAR DRIVE - SHAFT OUTPUT

310,000 in-lb (35,000 N-m) Intermittent Rating 160,000 in-lb (18,100 N-m) Continuous Rating
 Typical Applications: Industrial, Marine or Mobile Equipment

(913) 782-1238 (Tel)
 (913) 782-4206 (Fax)
Sales@Eskridgeinc.com
www.Eskridgeinc.com
 FORM: PS312L-AC

SHEET 2 OF 5

3-stage Option M-28 First Stage (Base Dimensions Identical to 2-Stage Option)

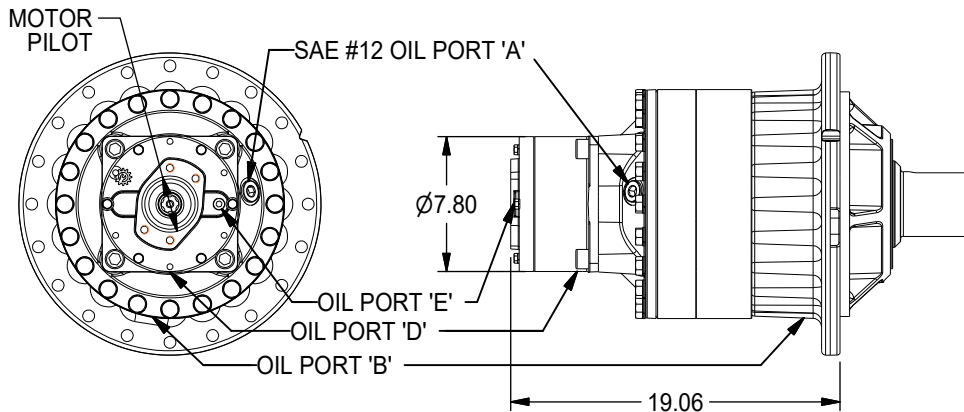

Available Ratios:

| | |
|------|------------|
| 76 | (75.94:1) |
| 83 | (82.62:1) |
| 99 | (98.76:1) |
| *102 | (102.32:1) |
| 111 | (110.93:1) |
| 121 | (120.70:1) |
| *149 | (149.47:1) |
| 151 | (150.93:1) |
| 164 | (164.21:1) |
| *203 | (203.36:1) |

Input Mounting:

- SAE "A" (2 & Modified 4 Bolt)
- SAE "B" (2 & 4 Bolt)
- SAE "C" (2 & 4 Bolt)

Input Spline:

- 2 (13T 16/32 DP Spline)
- 3 (1"-6B SAE Parallel Sided Spline)
- 4 (14T 12/24 DP Spline)
- 5 (15T 16/32 DP Spline)

*3-stage Option M-28 First Stage Code 4 Input for 102:1; 149:1; & 203:1

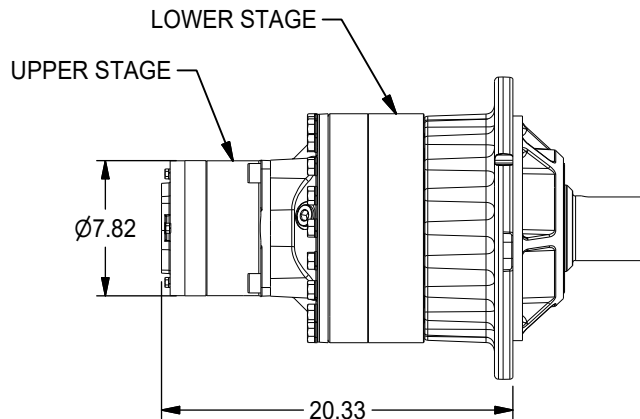

Oil Volume (3 Stage With M28)

Upper Stage

| LUBRICATION | ORIENTATION | HORIZONTAL: | VERTICAL: PINION DOWN | VERTICAL: PINION UP |
|--|-------------|----------------------|--------------------------------------|------------------------|
| QUANTITY | | 1.0 Pt/1.25 (Code 4) | 1.8 Pt/1.25 (Code 4) | 1.8 Pt/2.25 (Code 4) |
| OIL FILL LEVEL (GRADE GL-5 EP 80/90) | | FILL TO: PORT 'C' | FILL TO: 1.5" FROM COVER PORT 'E' | FILL TO: PORT 'D' |

Oil Volume Lower Stage

| LUBRICATION | ORIENTATION | HORIZONTAL: | VERTICAL: PINION DOWN | VERTICAL: PINION UP |
|--|-------------|-------------------|--------------------------------------|------------------------|
| QUANTITY | | 6.75 Pt | 12.75 Pt | 12.75 Pt |
| OIL FILL LEVEL (GRADE GL-5 EP 80/90) | | FILL TO: PORT 'A' | FILL TO: 1.5" FROM COVER PORT 'A' | FILL TO: PORT 'B' |

All Units Shipped Without Oil



312 GEAR DRIVE - SHAFT OUTPUT

310,000 in-lb (35,000 N-m) Intermittent Rating 160,000 in-lb (18,100 N-m) Continuous Rating
Typical Applications: Industrial, Marine or Mobile Equipment

(913) 782-1238 (Tel)
(913) 782-4206 (Fax)
Sales@Eskridgeinc.com
www.Eskridgeinc.com
FORM: PS312L-AC
SHEET 3 OF 5

Output Shaft Options *Values are shown as inches.*

D1 Output Shaft 20T 6/12 DP Spline

AVAILABLE OPTIONS:
Splined Hub: P/N 80-004-4132
Retainer Kit: P/N 80-018-0851

See Hubs & Pinions technical
data sheet for details

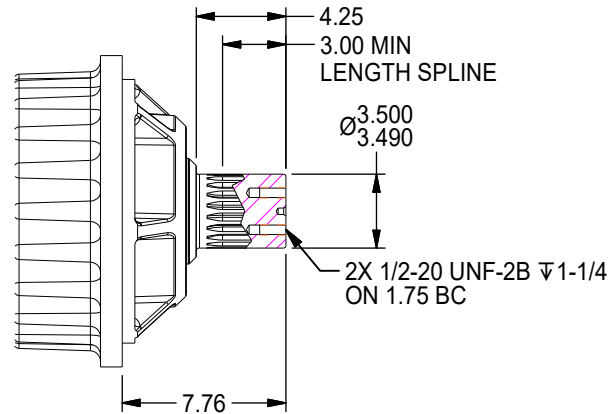

D2 Output Shaft Ø4.50 With 1" Keyway

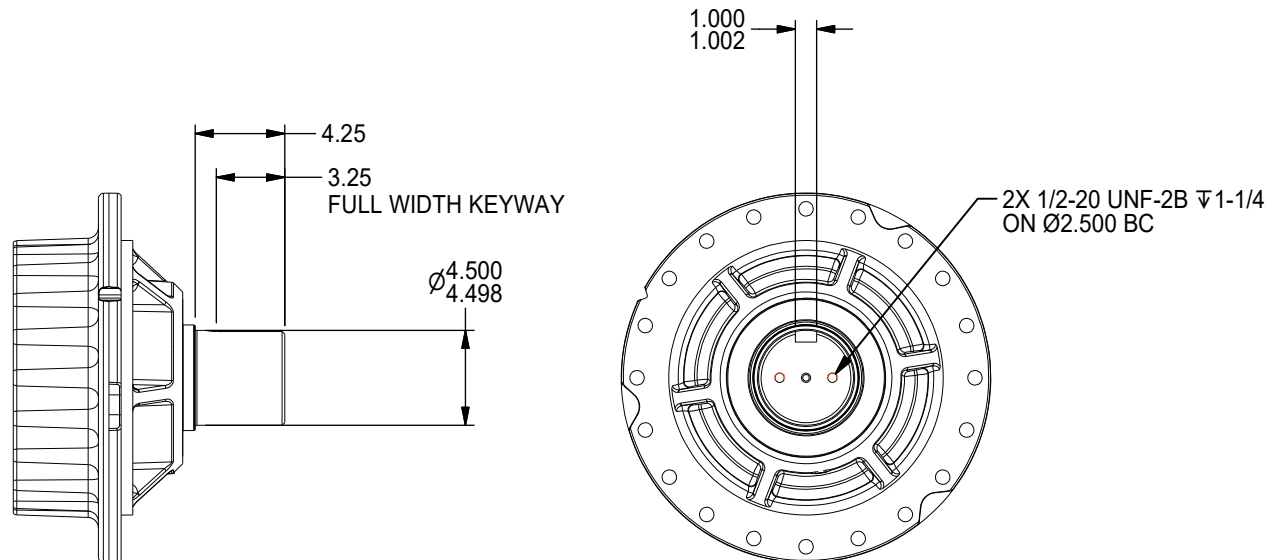



312 GEAR DRIVE - SHAFT OUTPUT

310,000 in-lb (35,000 N-m) Intermittent Rating 160,000 in-lb (18,100 N-m) Continuous Rating
 Typical Applications: Industrial, Marine or Mobile Equipment

(913) 782-1238 (Tel)
 (913) 782-4206 (Fax)
Sales@Eskridgeinc.com
www.Eskridgeinc.com
 FORM: PS312L-AC

SHEET 4 OF 5

Performance Ratings

Maximum Intermittent Output Torque: 310,000 in-lb (35,000 N-m)
 Continuous Output Torque: 160,000 in-lb (18,100 N-m)
 Maximum Input Speed: 3,000 RPM
 Maximum Operating Ambient Temperature: 110° F (43° C)
 Minimum Operating Ambient Temperature: -20° F (-28° C)

*Above ratings are general, mechanical ratings, not thermal ratings.
 Continuous duty may require additional cooling.
 Consult your Eskridge representative to determine
 ratings for your specific application or configuration*

Motor Mount Dimensions

| PILOT DIMENSIONS | BOLT CIRCLE |
|-----------------------|--|
| *SAE 'A' Ø3.251/3.255 | 4X 1/2-13 UNC-2B ∇.50 ON Ø4.1875 B.C. |
| *SAE 'B' Ø4.001/4.005 | 2X 1/2-13 UNC-2B ∇.50 ON Ø5.750 B.C. |
| SAE 'C' Ø5.001/5.004 | 4X 1/2-13 UNC-2B ∇1 ON Ø6.375 B.C. 2X 5/8-11 UNC-2B ∇1 ON Ø7.125 B.C. |
| SAE 'D' Ø6.000/6.004 | 4X 3/4-10 UNC-2B ∇1 ON Ø9.000 B.C. |

Approximate Unit Weight

Single Stage: -
 Two Stage: 415 lb
 Three Stage: 475 lb

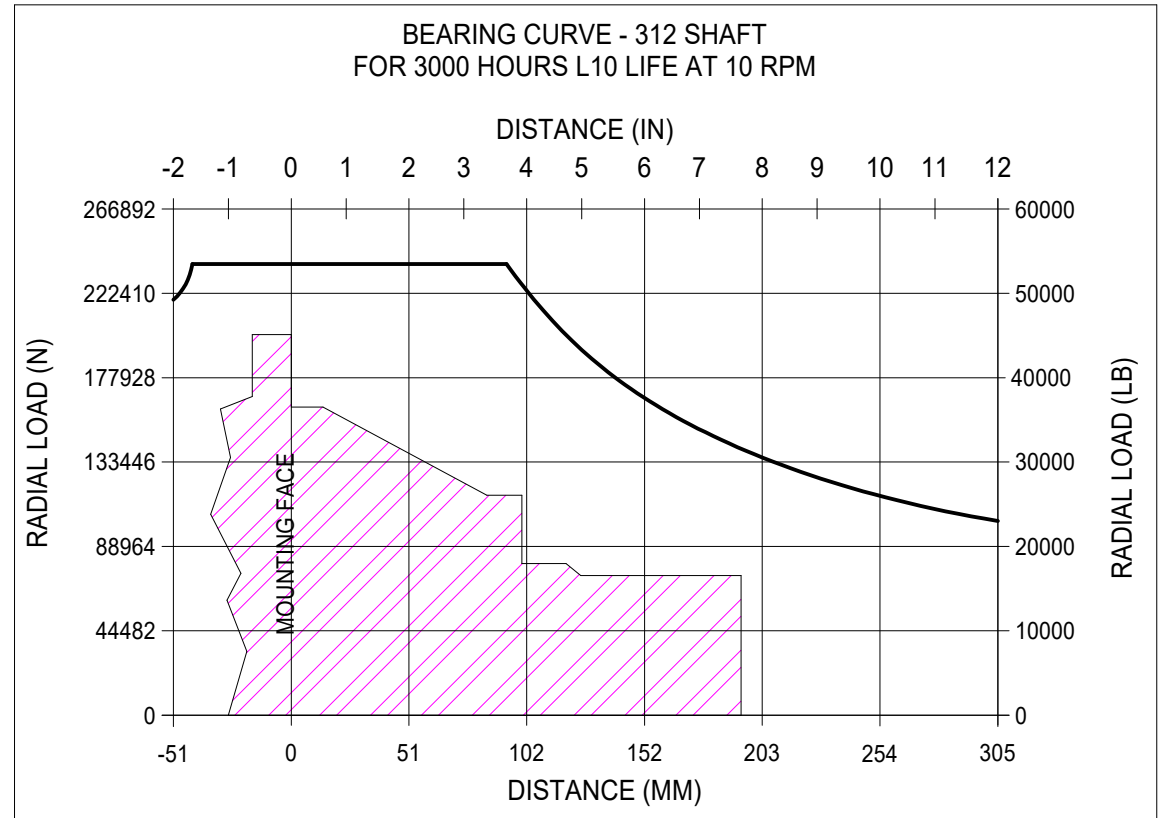

To adjust for loads and speeds other than those shown on above curve, use this formula:

$$\text{Adjusted Life (hours)} = 3000 \left(\frac{10 \text{ rpm}}{\text{Speed (Adjusted)}} \right) \times \left(\frac{\text{Load (Curve)}}{\text{Load (Adjusted)}} \right)^{10/3}$$



312 GEAR DRIVE - SHAFT OUTPUT

310,000 in-lb (35,000 N-m) Intermittent Rating 160,000 in-lb (18,100 N-m) Continuous Rating
Typical Applications: Industrial, Marine or Mobile Equipment

(913) 782-1238 (Tel)
(913) 782-4206 (Fax)
Sales@Eskridgeinc.com
www.Eskridgeinc.com
FORM: PS312L-AC

SHEET 5 OF 5

Ordering Information

Example Part Number: 312LAD1C4-40-Z

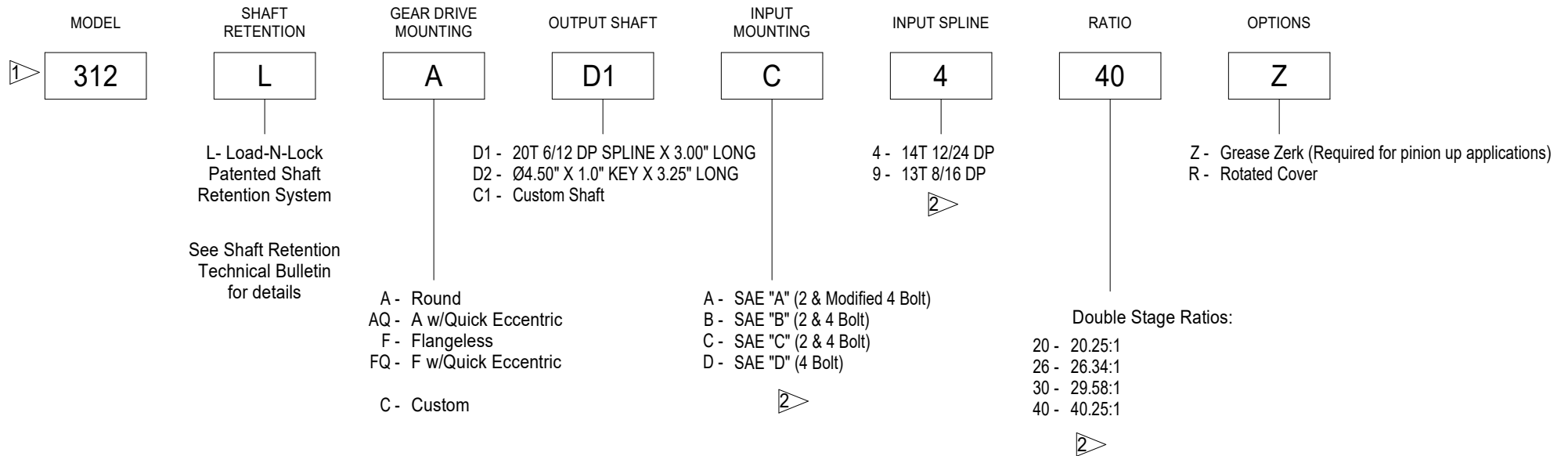

NOTES: ▷

1. TWO STAGE RATIO GEARBOX SHOWN IN EXAMPLE.
2. THREE STAGE INPUT MOUNTING, INPUT SPLINE AND RATIOS ARE SHOWN ON PAGE 2.