



133 GEAR DRIVE - SPINDLE OUTPUT

130,000 in-lb (14,688 N-m) Intermittent Rating 65,000 in-lb (7,344 N-m) Continuous Rating

Typical Applications: Industrial, Marine or Mobile Equipment

(913) 782-1238 (Tel)
(913) 782-4206 (Fax)
Sales@Eskridgeinc.com
www.Eskridgeinc.com
FORM: PS133SL-AA

SHEET 1 OF 4

133 1&2-Stage General Dimensions Flanged 'A' Option

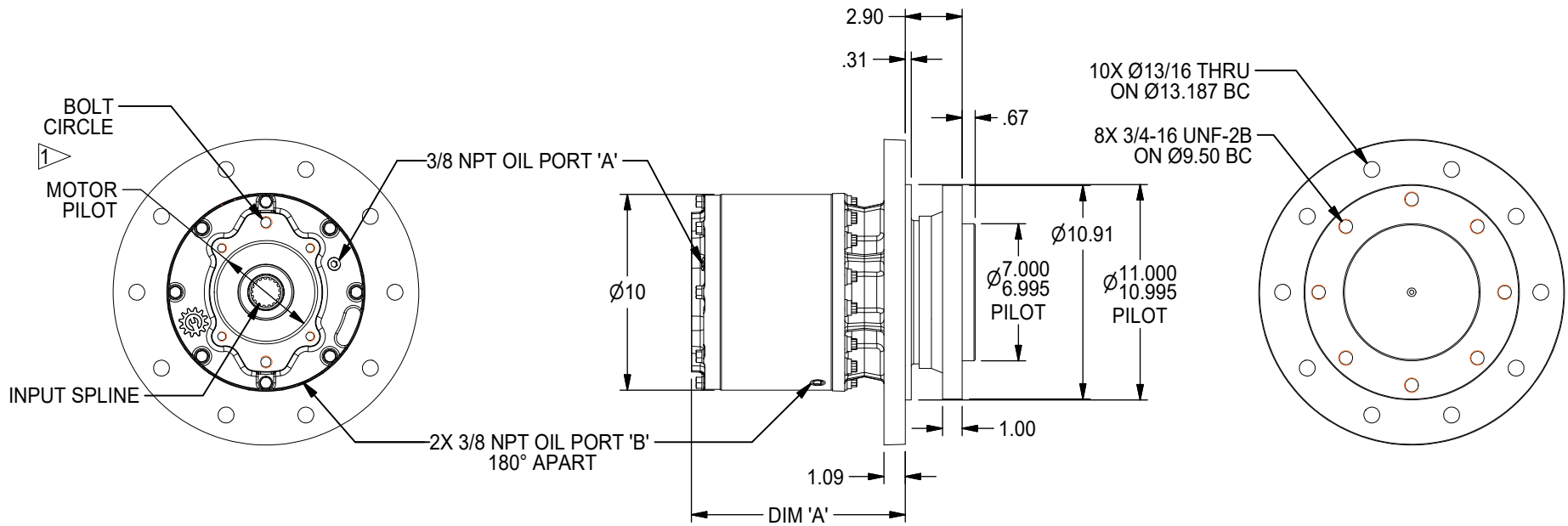



133 GEAR DRIVE - SPINDLE OUTPUT

130,000 in-lb (14,688 N-m) Intermittent Rating 65,000 in-lb (7,344 N-m) Continuous Rating

Typical Applications: Industrial, Marine or Mobile Equipment

(913) 782-1238 (Tel)
 (913) 782-4206 (Fax)
Sales@Eskridgeinc.com
www.Eskridgeinc.com
 FORM: PS133SL-AA

3-stage 'A' Option (Base Dimensions Identical to 1&2-Stage Options)

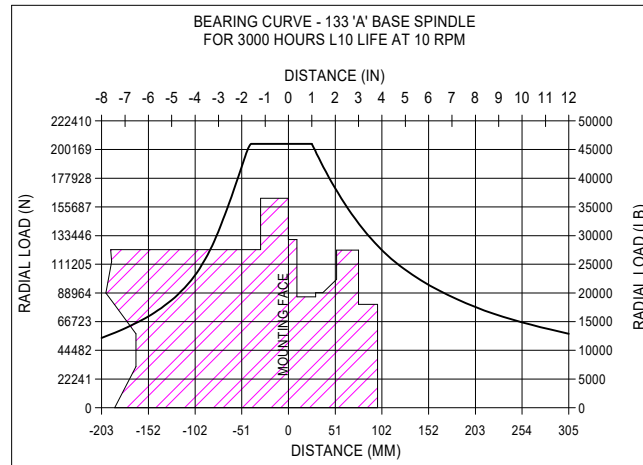
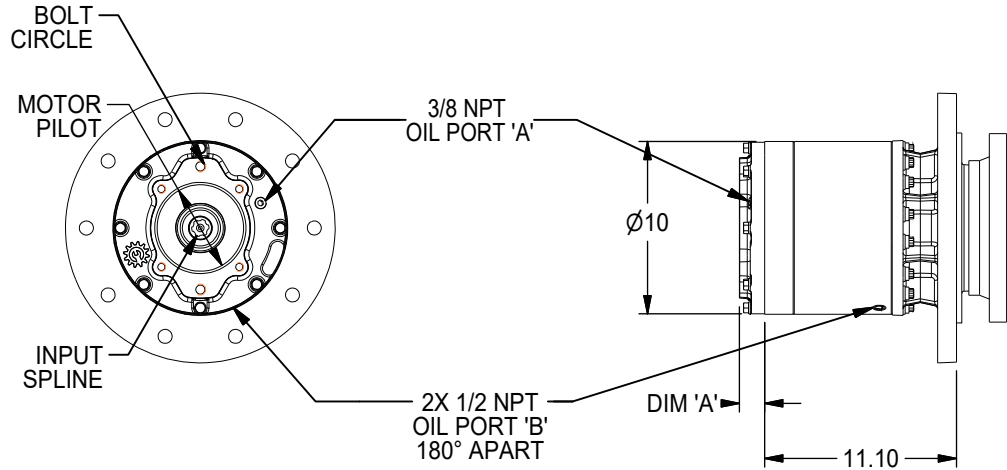

To adjust for loads and speeds other than those shown on above curve, use this formula:

$$\text{Adjusted Life (hours)} = 3000 \left(\frac{10 \text{ rpm}}{\text{Speed (Adjusted)}} \right) \times \left(\frac{\text{Load (Curve)}}{\text{Load (Adjusted)}} \right)^{10/3}$$



133 GEAR DRIVE - SPINDLE OUTPUT

130,000 in-lb (14,688 N-m) Intermittent Rating 65,000 in-lb (7,344 N-m) Continuous Rating

Typical Applications: Industrial, Marine or Mobile Equipment

(913) 782-1238 (Tel)
 (913) 782-4206 (Fax)
Sales@Eskridgeinc.com
www.Eskridgeinc.com
 FORM: PS133SL-AA

Performance Ratings

Maximum Intermittent Output Torque:	130,000 in-lb (14,688 N-m)
Continuous Output Torque:	65,000 in-lb (7,344 N-m)
Maximum Input Speed:	3,000 RPM
Maximum Operating Ambient Temperature:	110° F (43° C)
Minimum Operating Ambient Temperature:	-20° F (-28° C)

*Above ratings are general, mechanical ratings, not thermal ratings.
 Continuous duty may require additional cooling.
 Consult your Eskridge representative to determine
 ratings for your specific application or configuration.*

Motor Mount Dimensions

PILOT DIMENSIONS

BOLT CIRCLE

*SAE 'A' Ø3.251/3.253	4X 1/2-13 UNC-2B √5/8 ON Ø4.188 B.C.
*SAE 'B' Ø4.001/4.005	2X 1/2-13 UNC-2B √.50 ON Ø5.750 B.C.
SAE 'C' Ø5.001/5.004	4X 1/2-13 UNC-2B √1 ON Ø6.375 B.C. 2X 5/8-11 UNC-2B √1 ON Ø7.125 B.C.
SAE 'D' Ø6.000/6.004	4X 3/4-10 UNC-2B √1 ON Ø9.000 BC

4

Approximate Unit Weights (lbs)

Gear Drive Mounting	Stages		
	Single Planetary	Double Planetary	Triple Planetary
A	189	200	218
B	157	168	186
E	164	175	193
F	140	150	168
C	Consult Eskridge		

Oil Capacities

Position	Quantity		
	Single Planetary	Double Planetary	Triple Planetary
Vertical Shaft Down	5.0 pts Fill to: 1.5" From Port 'A'	5.0 pts Fill to: 1.5" From Port 'A'	6.9 pts Fill to: 1.5" From Port 'A'
Vertical Shaft Up	5.0 pts Fill to: Port 'B'	5.0 pts Fill to: Port 'B'	6.9 pts Fill to: Port 'B'
Horizontal	3.0 pts Fill to: Port 'A'	3.0 pts Fill to: Port 'A'	4.1 pts Fill to: Port 'A'

Units shipped without oil
 Use EP or API GL5 Designated Lubricants

Dimension 'A' Specifications

Input Spline Code	Ratio	Standard Input Mounting			
		SAE 'A'	SAE 'B'	SAE 'C'	SAE 'D'
2,3,5	4, 6, 19, 26, 36, 86, 117, 159	1.22	1.17	1.47	-
4	4, 6, 19, 26, 86, 117, 159	1.47	1.47	1.47	-
4	36, 216	2.72	2.27	2.72	-
ALL	33, 45, 147, 199, 270	2.72	2.27	2.27	-
7, 9	4, 6	-	-	-	1.69

NOTES: ▷

1. SPECIFICATION CALLED OUT IN MOTOR MOUNT DIMENSIONS SECTION.
2. VALUES ARE SHOWN IN INCHES.
3. OUTPUT SHAFT ROTATION SAME AS INPUT ROTATION.
4. ONLY AVAILABLE WITH SINGLE STAGE GEAR BOXES.



133 GEAR DRIVE - SPINDLE OUTPUT

130,000 in-lb (14,688 N-m) Intermittent Rating 65,000 in-lb (7,344 N-m) Continuous Rating

Typical Applications: Industrial, Marine or Mobile Equipment

(913) 782-1238 (Tel)
 (913) 782-4206 (Fax)
Sales@Eskridgeinc.com
www.Eskridgeinc.com
 FORM: PS133SL-AA

SHEET 4 OF 4

Ordering Information

Example Part Number: 133LAS1A2-19-Z

