

ESKRIDGE

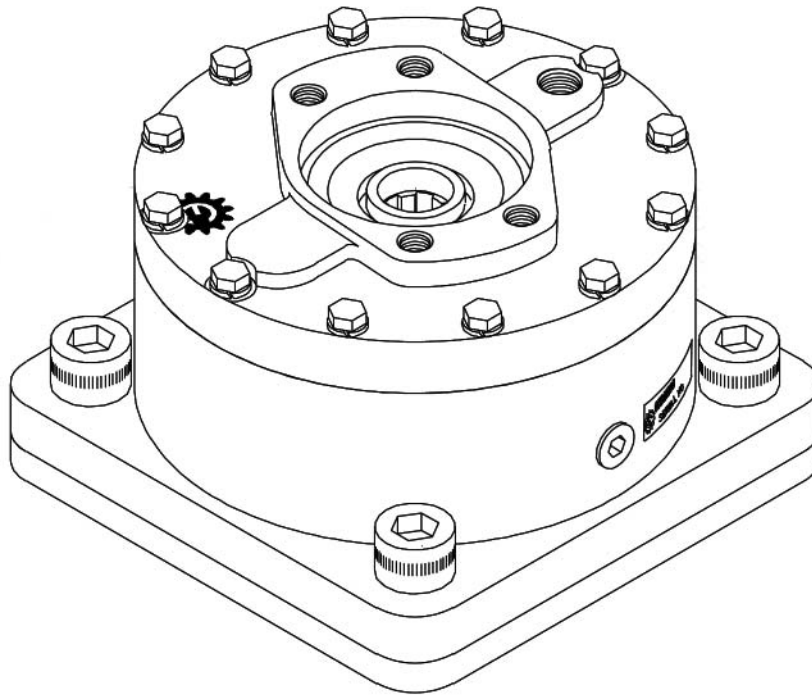

Example Part Number

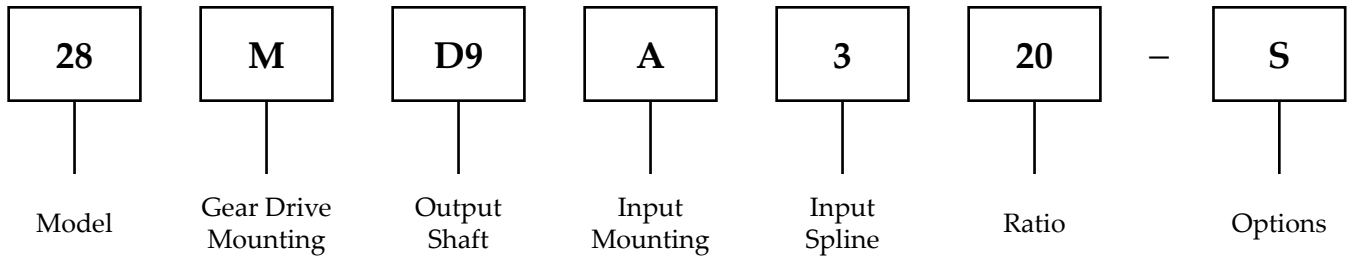

THIS SERVICE MANUAL IS EFFECTIVE
FROM: S/N 23042, AUGUST 1995
TO: CURRENT
REF: SM28M2-AA

M28 MODEL SERVICE MANUAL

SINGLE & DOUBLE STAGE PLANETARY GEAR DRIVE

This manual will primarily assist in disassembly and assembly procedures of major components for the Series M28 Planetary Gearbox, including double and single planetary models. Item numbers, indicated in parentheses throughout this manual, refer to the Eskridge Model M28 exploded parts breakdown drawing.

For any spare or replacement parts, contact your distributor or equipment manufacturer. Always try to have available the gear drive unit part number, serial number and date code on the serial tag; this information may be necessary for verification of any component part numbers. Component part numbers and/or manufacturing lot numbers may be stamped on individual parts; this information may also be helpful in identifying replacement components.

NOTE: The Model M28 is not a stand alone unit. It is only provided as an additional reduction stage on a larger (parent) geardrive; its part number, serial number and date code are of that parent unit.

LUBRICATION & MAINTENANCE

Change the oil after the first 50 hours of operation. Oil should be changed at 500 hour intervals thereafter. Use a GL-5 grade EP 89/90 gear oil (EP = "Extreme Pressure"). The gear drive should be partially disassembled to inspect gears and bearings at 1000 hour

<u>Operating Position</u>	<u>Ratio</u>	<u>Oil Capacity*</u>	<u>Oil Level</u>
Horizontal Shaft	Single	1.00 pint / 0.5 liters	To horizontal centerline of gear drive
Vertical Shaft	Single	1.75 pints / 0.9 liters	To midway on upper/primary gear set
Horizontal Shaft	Double	1.25 pints/ 0.6 liters	To horizontal centerline of gear drive
Vertical Shaft	Double	2.25 pints/ 1.1 liters	To midway on upper/primary gear set

*If provided with an optional output lip seal (30).



WARNING: While working on this equipment, use safe lifting procedures, wear adequate clothing and wear hearing, eye and respiratory protection.

CONTENTS

Example Part Number	1
Lubrication & Maintenance.....	2
Unit Disassembly Procedure.....	3
Secondary Planet Carrier Subassembly	3
*Primary Planet Carrier Subassembly	4
Case Subassembly.....	4
Unit Reassembly	5
Exploded View Drawing – Single Stage	6
Exploded View Drawing – Double Stage	7
Eskridge Product Warranty	8
Warranty Return Policy	8
Other Eskridge Products	9

Unit Disassembly Procedure

(Refer to exploded view drawings on Pages 6–7)

All parts should be carefully inspected as they are removed from unit. Scribe across mounting case (1) and cover (2) joint on outside of gearbox to assure proper orientation of oil fill and drain plugs, motor mounting, etc., as unit is reassembled.

- 1) Remove hydraulic motor and Eskridge Brake from gearbox. Drain oil.
- 2) Support the gearbox by the case (1) with the output shaft (3) free from weight of gearbox.
- 3) Remove the six 5/16 x 1 1/2" hex cap screws (22) and 5/16 lock washers (26), which retain cover (2) to mounting case (1).
- 4) Lift cover (2) off of unit and remove input gear (11), input thrust washer (21), and *thrust bearing (32).
- *5) Primary planet subassembly is now ready for removal (includes Items 5, 7, 13, 16, 20 & 24). Secondary sun gear (10) is splined to primary carrier (5) and may come out when removing planetary assembly; if not, remove sun gear. Remove thrust bearing (32). Remove primary ring gear (31).
- 6) The secondary planet assembly (includes Items 4, 6, 12, 14, 15, 19 & 23) is splined to the output shaft (3). It may now be lifted, by hand, from output shaft spline.
- 7) Flip case shaft-up and press shaft (3) and ball bearing (18) out of case.
- 8) Press out old seal (30).
- 9) If ball bearing (18) needs replacing, it will need to be pressed off of output shaft (3).

The unit is now disassembled into subassemblies.

The area(s) requiring repair or service should be identified by thorough inspection of the parts after they have been washed in solvent. If repair is necessary, refer to the individual repair section to follow.

Secondary Planet Carrier Subassembly

(Items 4, 6, 12, 15, 19 & 23)

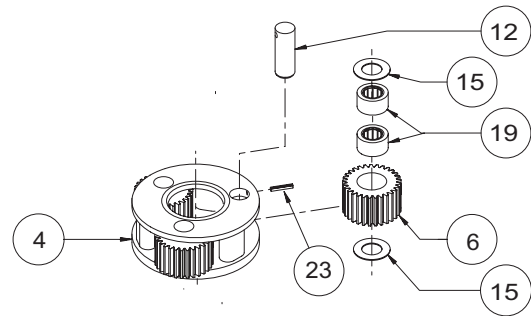

Disassembly

Rotate planet gears (6) to check for any abnormal noises or roughness in the planet bearings (19). At the same time, inspect planet gears for any damage or worn teeth. If replacement or further inspection is required, proceed as follows.

- 1) Drive the roll pins (23) completely into the planet shafts (12) using a 3/16" diameter punch. Press planet shafts out of carrier (4).

NOTE: Support only the carrier (4) while pressing out planet shafts.

- 2) Remove planet gears (6) and planet washers (15) from carrier (4).
- 3) If any of the planet bearings (19) need replacing, press them out of the planet gears.
- 4) Check planet shafts (12) for any abnormal wear, especially ones in which bearings needed to be replaced. If any abnormal wear is found, replace planet shaft.
- 5) Using a 3/16" diameter punch, drive roll pins out of planet shafts.
- 6) If required, press new planet bearings (19) into planet gears.
- 7) With a planet washer (15) on both sides of planet gear (6) and bearings (19) installed, slide gear into carrier (4). Insert planet shaft (12) through the carrier, planet gear and washers. During planet shaft installation, align roll pin hole in planet shaft with chamfered edge facing out, to the roll pin hole in outside diameter of carrier.

NOTE: Inserting a 3/16" diameter punch in the planet shaft roll pin hole will help in the alignment of holes between planet shaft and carrier during Step 7.

- 8) Once holes are properly aligned, drive a roll pin (23) through primary carrier and into planet shaft to retain parts. Use a drift to drive roll pin flush to carrier and to prevent striking planet gear teeth.

Repeat the same procedure for remaining gears.

*Step applies only to double planetary models.

*Primary Planet Carrier Subassembly

(Items 5, 7, 13, 16, 20 & 24)

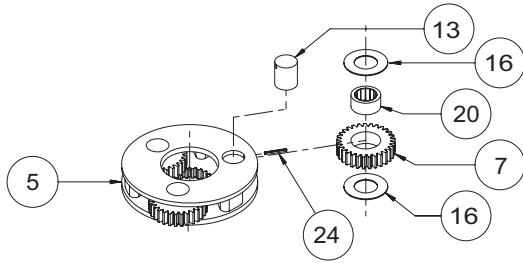

Disassembly & Repair

Follow the same procedure as that for the Secondary Planet Carrier Subassembly, except substitute item numbers as indicated: primary carrier (5), primary planet gear (7), primary planet shaft (13), primary planet washer (16), primary planet bearing (20) and primary roll pin (24). Note that roll pins are 1/8" in diameter.

Case Subassembly

(Items 1 & 27)

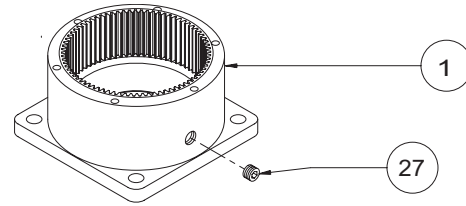

Disassembly & Repair

Clean all foreign material from magnetic oil plug (27) located inside of mounting case (1). Add a small amount of pipe thread compound to pipe plug before installing back into case.

All subassembly service or repairs should be complete at this time. Continue to Unit Assembly.

*Step applies only to double planetary models.

Unit Reassembly

(Refer to exploded drawings on Pages 6–7)

- 1) If equipped with optional seal **(30)**, turn case **(1)** upside down and position it so that the side with the threaded holes is resting on the press table. Press shaft seal **(30)** into case until it is flush with bottom of counterbore. Use a press fixture, if possible, to eliminate distorting seal. If press fixture is not available, a hammer and flat-ended drift may be used by tapping outer edge of seal lightly and alternating sides.
 - 2) Turn case input-side up supported 2" off of table. Install shaft **(3)**, bearing **(18)**, and retaining ring **(25)** assembly by pressing outer race of bearing into case bore. Make sure that lip seal **(30)** is properly seated on shaft.
 - 3) Place carrier thrust bearing **(32)** on internal end of the shaft. Install secondary carrier **(4)** assembly into unit; carrier assembly should be installed with hub side down (24 tooth spline). Rotate carrier assembly back and forth to mesh secondary planet gear teeth **(6)** with case **(1)** teeth. Once teeth mesh, let secondary carrier slide down until it makes contact with the output shaft spline. The carrier splined hub **(4)** should spline onto output shaft **(3)**. Carrier hub will rest on top of retaining ring **(25)** when splines are fully engaged. Install carrier thrust washer **(14)**.
 - *4) Install sun gear **(10)** in secondary carrier. Install primary carrier assembly in unit so that its splined hub meshes with sun gear.
 - 5) Install input gear **(11)** in unit. Refer to the exploded view drawing (Pages 6–7) for proper orientation.
 - *6) Place thrust bearing **(33)** over input gear **(11)**.
 - 7) Place input thrust washer **(21)** over input gear **(11)**.
 - *8) Grease a new o-ring **(29)** and install in bottom (internal stepped) end of ring gear **(31)**. Refer back to scribe marks made across external join prior to Disassembly Procedure. Line up scribe marks between cover and case **(1)**, so that orientation of motor mount holes and oil plugs are back to their original positions. Place ring gear over primary carrier onto top of case **(1)** so that it meshes with planet gears **(7)**.
 - 9) Fill unit with proper level of a GL-5 grade EP 80-90 gear oil; see Page 2 for details. Proper oil level will measure to middle of primary planet gears.
 - 10) Grease a new o-ring **(29)** and install into bottom of cover **(2)**. Refer back to scribe marks made across external joint prior to Disassembly Procedure. Line up scribe marks between cover and case **(1)** so that orientation of motor mount holes and oil plugs are back to their original positions.
- NOTE: Be certain o-ring (29) stays seated in cover during Step 10.**
- 11) Install all six of the 5/16 lock washers **(26)** and the 5/16 hex cap screws **(22)** and torque to 20 ft-lbs.

THE GEARBOX IS NOW READY TO USE.

*Step applies only to double planetary models.

Exploded View Drawing – Single Stage

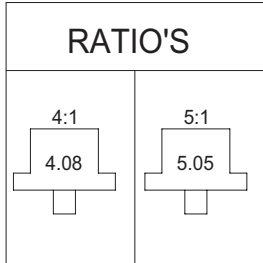

MODEL M28
SINGLE PLANETARY



EFFECTIVE
FROM: S/N 23042 08/25/95
TO: (CURRENT)

PART NUMBER	PART NUMBER	QTY.	ITEM	C O D E	DESCRIPTION
←	28-004-3624	1	1		M28 CASE
←	85-004-1513	1	2	A	COVER-SAE 'A'
←	85-004-1503			B	COVER-SAE 'B' 2-BOLT
←	28-004-1013			C	COVER-SAE 'C' 4-BOLT
←	28-004-4222	1	3		OUTPUT SHAFT
←	50-004-1062	1	4		CARRIER-SECONDARY
←	85-004-1051	3	6		PLANET GEAR-SEC.
←	85-004-1552	1	11	1	INPUT GEAR 21T,20/40 D.P.SPLINE
←	85-004-1382			2	INPUT GEAR 13T,16/32 D.P.SPLINE
←	85-004-1272			3	INPUT GEAR SAE 1"-6B SPLINE
←	85-004-1292			4	INPUT GEAR 14T,12/24 D.P.SPLINE
←	85-004-1562			5	INPUT GEAR 15T,16/32 D.P.SPLINE
←	85-004-1592			6	INPUT GEAR 1"DIA X .25" KEY
←	71-004-0121	3	12		PLANET SHAFT-SECONDARY
←	50-004-1011	1	14		THRUST WASHER-SEC.CUP
←	85-004-1181	6	15		THRUST WASHER-(SEC.PLANET GEAR)
←	01-100-0280	1	18		BEARING-BALL
←	01-105-0010	6	19		BEARING-SEC.PLANET
←	50-004-1091	1	21		THRUST WASHER-INPUT
←	01-150-1400	6	22		HEX CAPSCREW 5/16-18 X 1.5 GR8
←	01-153-0210	3	23		ROLLPIN-SECONDARY 3/16 X 7/8
←	01-160-0250	1	25		RETAINING RING
←	01-166-0110	6	26		LOCKWASHER 5/16 MED
←	01-207-0070	2	27		PIPE PLUG-MAG. 3/8 NPT-SOC HD
←	01-402-0560	1	29		O-RING 167 MM X 3 MM
←	01-405-0620	(1)	30		SEAL-SHAFT (OPTIONAL)
←	28-004-1021	1	32		THRUST BEARING
←	01-216-0070	(1)	35		AIR VENT 3/8 NPT (OPTIONAL)
-	-	-	-		-

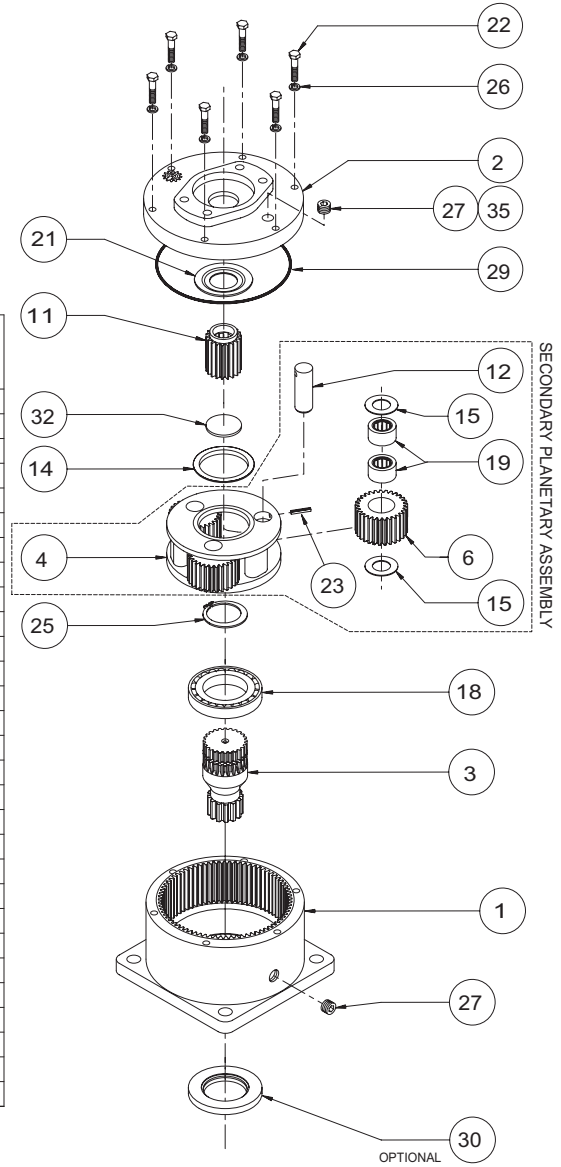

E.C.N.2197
X28M1-AC DATE: 04-15-04

Exploded View Drawing – Double Stage

MODEL M28
DOUBLE PLANETARY



EFFECTIVE
FROM: S/N 23042 08/25/95
TO: (CURRENT)

RATIO'S			
16.65:1 4.08 4.08	20.62:1 5.05 4.08	20.62:1 4.08 5.05	25.53:1 5.05 5.05
		INVERTED	

CODE	DESCRIPTION	ITEM	QTY.	PART NUMBER	PART NUMBER	PART NUMBER	PART NUMBER
	M28 CASE	1	1	28-004-3624			
A	COVER-SAE 'A'			85-004-1513			
B	COVER-SAE 'B' 2-BOLT	2	1	85-004-1503			
C	COVER-SAE 'C' 4-BOLT			28-004-1013			
	OUTPUT SHAFT	3	1	28-004-4222			
	CARRIER-SECONDARY	4	1	50-004-1062	50-004-1052	50-004-1052	50-004-1052
	CARRIER-PRIMARY	5	1	50-004-1082	50-004-1072	50-004-1082	50-004-1072
	PLANET GEAR-SEC.	6	3	85-004-1051	85-004-1051	85-004-1041	85-004-1041
	PLANET GEAR-PRI.	7	3	85-004-1031	85-004-1021	85-004-1031	85-004-1021
	SUN GEAR-SECONDARY	10	1	85-004-1412	85-004-1092	85-004-1072	85-004-1072
1	INPUT GEAR 21T,20/40 D.P.SPLINE			85-004-1402		85-004-1402	N/A
2	INPUT GEAR 13T,16/32 D.P.SPLINE			85-004-1102	85-004-1062		85-004-1062
3	INPUT GEAR SAE 1"-6B SPLINE			85-004-1122	85-004-1112		85-004-1112
4	INPUT GEAR 14T,12/24 D.P.SPLINE			85-004-1533		85-004-1533	N/A
5	INPUT GEAR 15T,16/32 D.P.SPLINE			85-004-1542	85-004-1422		85-004-1422
5	INPUT GEAR 1"DIA X .25" KEY			85-004-1582		85-004-1582	N/A
	PLANET SHAFT-SECONDARY	12	3	71-004-0121			
	PLANET SHAFT-PRIMARY	13	3	81-004-0071			
	THRUST WASHER-SEC.CUP	14	1	50-004-1011			
	THRUST WASHER-(SEC.PLANET GEAR)	15	6	85-004-1181			
	THRUST WASHER-(PRI.PLANET GEAR)	16	6	81-004-1561			
	BEARING-BALL	18	1	01-100-0280			
	BEARING-SEC.PLANET	19	6	01-105-0010			
	BEARING-PRI.PLANET	20	3	01-105-0410			
	THRUST WASHER-INPUT	21	1	50-004-1091			
	HEX CAPSCREW 5/16-18 X 2.75 GR8	22	6	01-150-1490			
	ROLLPIN-SECONDARY 3/16 X 7/8	23	3	01-153-0210			
	ROLLPIN-PRIMARY 1/8 X 1	24	3	01-153-0080			
	RETAINING RING	25	1	01-160-0250			
	LOCKWASHER 5/16 MED	26	6	01-166-0110			
	PIPE PLUG-MAG. 3/8 NPT-SOC HD	27	2	01-207-0070			
	O-RING 167 MM X 3 MM	29	1	01-402-0560			
	SEAL-SHAFT (OPTIONAL)	30	(1)	01-405-0620			
	RING GEAR	31	1	85-004-1313			
	THRUST BEARING	32	1	28-004-1021			
	THRUST BEARING	33	1	01-112-0230			
	AIR VENT 3/8 NPT (OPTIONAL)	35	(1)	01-216-0070			
-	-	-	-	-	-	-	-

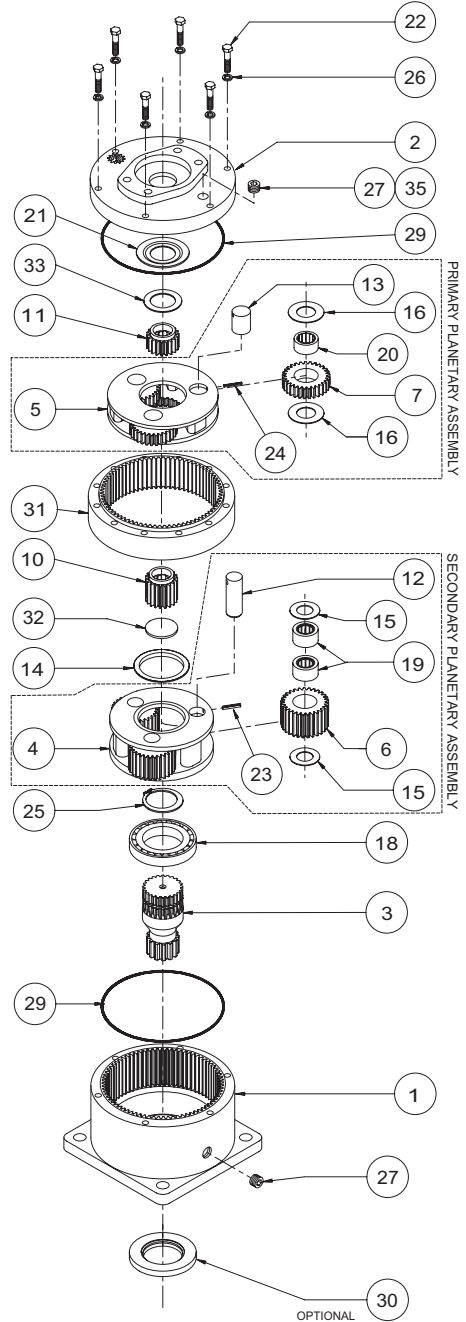

▽ FOR 20:1 RATIO, INPUT CODES 1, 4 AND 6 REQUIRE "INVERTED" RATIO CARRIER ASSEMBLIES.

ECN 2197
X28M2-AD DATE: 04-15-04

Eskridge Product Warranty

ESKRIDGE, INC. ("Eskridge") warrants to its original purchaser ("Customer") that new component parts/units ("Units") sold by Eskridge will be free of defects in material and workmanship and will conform to standard specifications set forth in Eskridge sales literature current at the time of sale or to any custom specifications acknowledged by written Customer approval of drawings, SUBJECT TO THE FOLLOWING QUALIFICATIONS AND LIMITATIONS:

1. Prior to placing Units in service, the Customer shall provide proper storage such that foreign objects (e.g., rain or debris) cannot enter any Units via entry ports which are normally closed during operation.
2. The Customer must notify Eskridge in writing of any claim for breach of this warranty promptly after discovery of a defect. The warranty period shall commence when a unit is placed in service and shall expire upon the earlier of
 - a. the expiration of twelve (12) months from the date of Commencement of Service (as defined in Paragraph 4)
 - b. the completion of one thousand (1000) hours of service of the Units
 - c. the expiration of six (6) months after the expiration of any express warranty relating to the first item of machinery or equipment in which the Units are installed or on which it is mounted, or
 - d. the installation or mounting of the Units in or on an item of machinery or equipment other than the first such item in which the Units are installed or on which the Units are mounted.
3. Units shall be deemed to have been placed in service (the "Commencement of Service") at the time the machinery or equipment manufactured or assembled by the Customer and in which the Units are installed or on which the Units are mounted is delivered to the Customer's dealer or the original end-user, which ever receives such machinery or equipment first.
4. This warranty shall not apply with respect to Units which, upon inspection by Eskridge, show signs of disassembly, rework, modifications, lack of lubrication or improper installation, mounting, use or maintenance.
5. Eskridge makes no warranty in respect to hydraulic motors mounted on any Units. Failure of any such motor will be referred to the motor manufacturer.
6. Claims under this warranty will be satisfied only by repair of any defect(s) or, if repair is determined by Eskridge in its sole, absolute and uncontrolled discretion to be impossible or impractical, by replacement of the Units or any defective component thereof. No cash payment or credit will be made for defective materials, workmanship, labor or travel. IN NO EVENT SHALL ESKRIDGE BE LIABLE FOR INCIDENTAL OR CONSEQUENTIAL DAMAGES OF ANY KIND OR NATURE, FOR WHICH DAMAGES ARE HEREBY EXPRESSLY DISCLAIMED.
7. From time to time, Eskridge may make design changes in the component Units manufactured by it without incorporating such changes in the component Units previously shipped. Such design changes shall not constitute an admission by Eskridge of any defects or problems in the design of previously manufactured component Units.
8. All freight charges on Units returned for warranty service are the responsibility of the Customer.

Warranty Return Policy

1. Any part/Unit(s) returned to Eskridge must be authorized by Eskridge with an assigned return (CSR) number.
2. All Units shall be returned freight prepaid.
3. Any Units qualifying for warranty will be repaired with new parts free of charge (except for freight charges to Eskridge as provided above).
4. If Units are found to be operable, you have two options:
 - a. The Units can be returned to you with a service charge for inspection, cleaning, and routine replacement of all rubber components and any other Units that show wear;
 - b. We can dispose of the Unit(s) at the factory if you do not wish it to be returned.

NOTE: Any order of Units by customer shall only be accepted by Eskridge subject to the terms stated herein. Any purchase order forms used by Customer (to accept this offer to sell) which contain terms contrary to, different from, or in addition to the terms herein shall be without effect, and such terms shall constitute material alteration of the offer contained herein under K.S.A 84-2-207 (2)(b), and shall not become part of the contract regarding the sale of the Units.

The foregoing warranty is the sole warranty made by Eskridge with respect to any Units and is in lieu of any and all other warranties, expressed or implied. There are no warranties which extend beyond the description on the face hereof without limiting the generality of the foregoing, Eskridge expressly disclaims any implied warranty of merchantability or fitness for any particular purpose, regardless of any knowledge Eskridge may have of any particular use or application intended by the purchaser. The suitability or fitness of the Units for the customer's intended use, application or purpose and the proper method of installation or mounting must be determined by the customer.

OTHER ESKRIDGE PRODUCTS

PLANETARY GEAR DRIVES

SERIES	TORQUE RATING (IN-LB) MAX. INTERMITTENT
20 - SHAFT OUTPUT	20,000
28 - SHAFT OUTPUT	50,000
50 - SHAFT OUTPUT OR SPINDLE OUTPUT	50,000
65 - SHAFT OUTPUT	65,000
105 - SHAFT OUTPUT	105,000
130/133 - SHAFT OUTPUT OR SPINDLE OUTPUT	130,000
150 - SHAFT OUTPUT	150,000
250/252 - SHAFT OUTPUT OR SPINDLE OUTPUT	250,000
440 - SHAFT OUTPUT, SPINDLE OUTPUT OR WHEEL DRIVE	440,000
600 - SHAFT OUTPUT, SPINDLE OUTPUT OR WHEEL DRIVE	600,000
1000 - SHAFT OUTPUT, SPINDLE OUTPUT OR WHEEL DRIVE	1,000,000

MULTIPLE DISC BRAKES

SERIES	FEATURES	TORQUE RATING (IN-LB)
10 - INTEGRAL BRAKE	SAE B	TO 4,800
90B	SAE B	TO 4,800
90BA	SAE B, ADJUSTABLE TORQUE	TO 4,800
92B	SAE B, LOW PROFILE	TO 2,800
93 (931 OR 932)	FOR NICHOLS MOTORS	TO 6,100
95C	SAE C	TO 12,000
98D	SAE D	TO 25,000

PLANETARY AUGER DRIVES, ANCHOR DRIVES & DIGGERS

SERIES	MODELS	TORQUE RATING (FT-LB)
D50	1500, 2500 & 5000	1,500 - 5,000
76	BA & BC, 2-SPEED	8,000 - 12,500
77	BA, BC & BD	6,000 - 12,500
78	35 & 48, 2-SPEED	9,000 - 12,500
75	38 & 51, 2-SPEED	16,500 - 20,000
D600	D600	50,000
D1000	D1000	83,000

