

ESKRIDGE

S77 PLANETARY AUGER DRIVE SERVICE AND REPAIR MANUAL

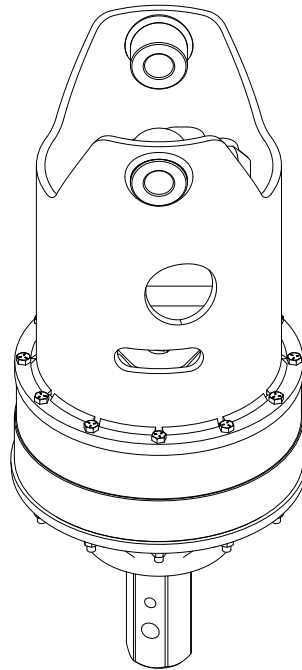

Example Part Number

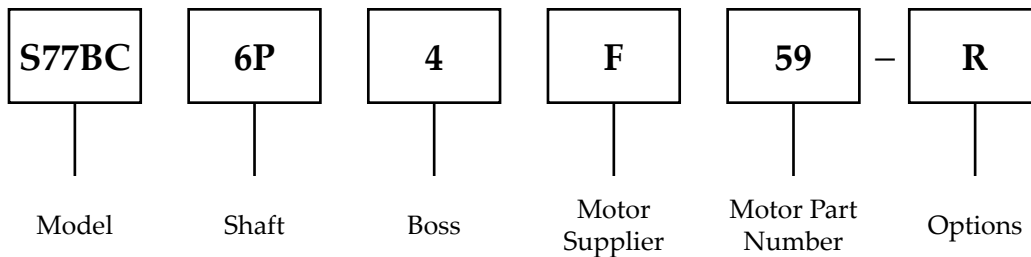

THIS SERVICE MANUAL IS EFFECTIVE
FROM: S/N 38045, JAN. 2002
TO: CURRENT
REF: SMS77-BC_AB

S77 SERVICE MANUAL

SINGLE SPEED PLANETARY AUGER DRIVE

This manual will assist in disassembly and assembly of major components for all Model S77 Planetary Auger Drives. Item numbers, indicated in parentheses throughout this manual, refer to the Eskridge Model S77 exploded parts breakdown drawings. Individual customer specifications (bail assembly, output shaft, hydraulic motor, etc.) may vary from exploded drawing and standard part numbers shown; if applicable, refer to individual customer drawings for details.

LUBRICATION & MAINTENANCE

Change the oil after the first 50 hours of use and at 500 hour intervals thereafter. Gear drives in auger drives require GL-5 grade EP 80/90 gear oil for lubrication. The manufacturer recommends that the unit be partially disassembled to inspect gears, splines and bearings at 1000 hour intervals.

The oil capacity of this unit is 6.5 pints. Proper oil level will measure to middle of primary cluster gears when auger drive is in vertical position.

To check the oil in fully assembled units, fill the gear drive with EP 80/90 gear oil until it runs out of the fill plug while the auger drive is leaning approximately 3 1/2 inches from vertical (approximately 7°); see the illustration to the right.

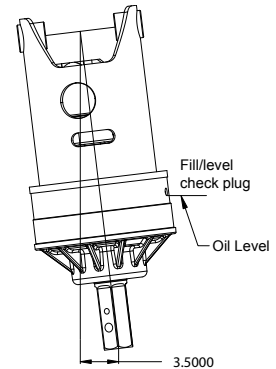

WARNING: While working on this equipment, use safe lifting procedures, wear adequate clothing and wear hearing, eye and respiratory protection.

CONTENTS

Example Part Number	1
Lubrication & Maintenance.....	2
Unit Disassembly Procedure.....	3
Primary Planet Carrier Subassembly	3
Secondary Planet Carrier Subassembly	4
Top Case Subassembly	4
Bearing Carrier Subassembly	5
Unit Reassembly Procedure.....	5
Exploded View Drawing	7
Eskridge Product Warranty	8
Warranty Return Policy	8
Eskridge Product Line	9

Unit Disassembly Procedure

(Refer to exploded view drawing on Page 7)

- 1) Scribe a diagonal line across the outside of the auger drive, from the bail assembly (20) to the bearing carrier (2), to assure proper orientation of parts as they are reassembled.
- 2) To drain oil, position unit on its shaft and remove oil plug (41) located in the bearing carrier (1). To help ventilate oil while draining, loosen or remove drain plug (41) in top case (1). Maximum drainage occurs when oil is warm.

NOTE: Particular care should be taken when placing the unit in a position for servicing. Unit should be blocked up so that weight of the unit is resting on the bearing carrier (2). This fixture must be secure so that the auger drive will not tip over during disassembly and assembly procedures.

- 3) Remove the twelve hex-head cap screws (29) and hex-flange nuts (34) from bail assembly (20). Lift bail assembly from unit.

NOTE: There are no bolts retaining the major components together; proceed with caution when moving the unit.

- 4) Remove the two capscrews (31) and lock washers (40) from hydraulic motor (50). Remove motor from unit. Check o-ring (43) for damage.
- 5) Remove top case (1), input gear (14) and o-ring (44).
- 6) Lift the primary planet carrier assembly out of the unit (includes Items 7, 9, 11, 17, 23 & 33).
- 7) If sun gear (12) has not been removed from auger drive, do so now. (Sometimes the sun gear remains in the primary carrier (7).)
- 8) Remove secondary ring gear (4) and o-ring (44).
- 9) The output shaft (49) and secondary planet carrier assembly may now be removed as follows:
 - a) The secondary planet carrier (6) spline is a press fit onto output shaft (49) spline. Bearing carrier (2) should be set on plate or table with output shaft protruding downward through hole in table.
 - b) Loosen, but do not remove, shaft retaining cap screws (15).

NOTE: Care should be taken not to damage output shaft or injure your feet when shaft falls out of case.

- c) Press output shaft out bottom of case by applying press load to top end of cap screws (15). Remove cap screws to allow shaft to pass through case.
- 10) Lift the secondary planet assembly out of the unit (includes Items 6, 8, 10, 18, 24 & 33). Use a puller, if needed.
 - 11) The unit is now disassembled into subassemblies. The area(s) requiring repair should be identified by thorough inspection of the parts after they have been cleaned and dried.

Primary Planet Carrier Subassembly

(Items 7, 9, 11, 17, 23 & 33)

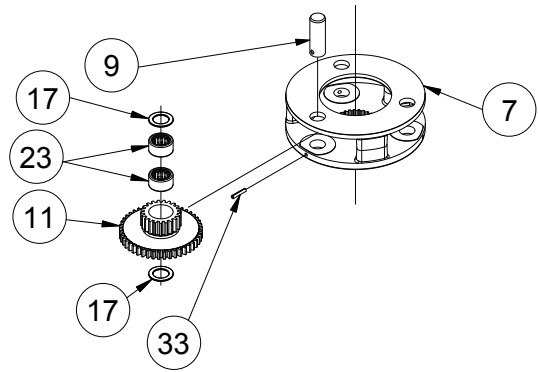

- 1) Rotate cluster gears (11) to check for abnormal noise or roughness in bearings (23) or planet pins (9). If further inspection or replacement is required, proceed as follows.
- 2) Drive roll pins (33) completely into planet pins (9).
- 3) Press or drive planet pins (9) out of carrier (7).
- 4) Remove cluster gears (11) and washers (17) from the carrier (7).
- 5) If the planet bearings (23) require replacement, press them out of the cluster gears (11) and replace with new ones.
- 6) Check primary planet pins (9) for any abnormal wear, especially ones where bearings needed to be replaced. If any abnormal wear is found, replace planet shafts.
- 7) Remove the roll pins (33) from planet pins (9).
- 8) With washers (17) on both sides of the cluster gear (11) and with bearings (23) installed, slide gear into the carrier (7). Be sure the large gear side of cluster gear is toward the splined side of carrier. Insert the planet pin (9) through the carrier, washers and planet gear.
- 9) Planet pins (9) should be installed with chamfered end of 1/8 inch hole toward outside diameter of the carrier (7). This will aid in alignment of holes while inserting roll pins (33).
- 10) Drive three roll pins (33) through the carrier holes and into the planet shafts to retain the parts.

Secondary Planet Carrier Subassembly

(Items 6, 8, 10, 13, 18, 21, 24 & 33)

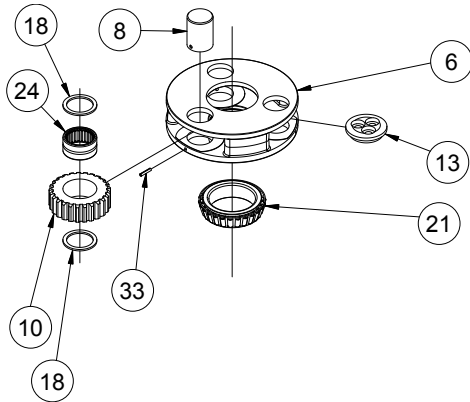

Disassembly

- 1) Rotate the secondary planet gear (10) to check for abnormal noise or roughness in planet bearings (24) or secondary planet shafts (8). If further inspection or replacement is required, proceed as follows.
- 2) Drive roll pins (33) into secondary planet shafts (8).
- 3) Press or drive secondary planet shafts out of secondary carrier (6).
- 4) Slide secondary planet gears (10) along with planet washers (18) out of secondary carrier (6).

Reassembly

- 1) Place carrier (6) with hub down. Place bearing retainer plate (13) in bottom of carrier. Insert secondary planet gears (10).
- 2) Turn carrier (6) over while using the planet gears (10) to hold retainer plate (13) in place.
- 3) Remove one planet gear (10) and insert bearing (24). Install two washers (18) (one on either side of the planet gear). Place in carrier and install planet shaft (8) and roll pin (33). Repeat for two remaining gears.

NOTE: Press bearing onto hub by pressing on inner race only. DO NOT press on roller cage: it may damage bearing.

- 4) If tapered inner bearing cone (21) on secondary carrier (6) hub must be replaced, it may be removed using a gear puller. Then, press a new bearing cone onto the hub, making sure bearing shoulder is tight against the hub shoulder.

Top Case Subassembly

(Items 1, 5, 32, 41 & 47)

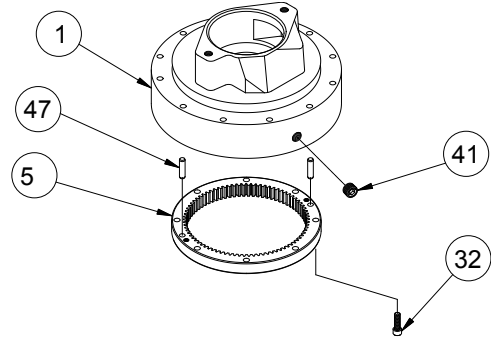

Disassembly

- 1) Inspect primary ring gear (5) for abnormal wear or damaged teeth. If replacement is required, remove eight socket head cap screws (32) from ring gear. Primary ring (5) is doweled into top case (1). Use puller holes provided to thread two 3/8-16 bolts into ring gear (5) until part has completely separated from top case (1).

Reassembly

- 1) If installing a new primary ring gear (5), always install new dowel pins (47) into ring gear before reassembling top case (1).
- 2) Use thread locking compound, such as Loctite 242, in the 3/8-16 threaded holes of the top case (1).
- 3) Install the 3/8-16 capscrews (32) and tighten to a torque of 30 ft-lbs in a cross-wise pattern.

Bearing Carrier Subassembly

(Items 2, 3, 25, 30, 34, 41, 46 & 49)

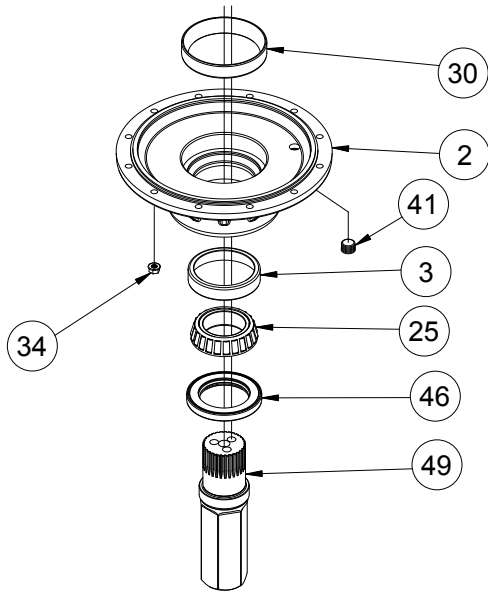

Disassembly

NOTE: If reusing old bearing cone, do not damage roller cage by pulling on it.

- 1) If outer bearing cone (25) needs to be replaced a puller may be used.
- 2) Remove shaft seal (46) for inspection or replacement. Lubricate inner lip of new shaft seal (46) and slide the seal onto the shaft (49) until it fits snugly over shaft seal diameter with the open side toward the inside of the auger drive.
- 3) Inspect inner and outer bearing cups and bearing (3, 30 & 25); replace if necessary.

Reassembly

NOTE: Press bearing cone onto output shaft by pressing on inner race only. DO NOT press on roller cage or it may damage bearing.

- 1) If outer bearing cone (25) was removed for replacement, press a new bearing cone (large end down, as shown) onto the shaft until it seats against the shoulder.
- 2) Place the bearing carrier (2) (output shaft side up, opposite shown) on the press table.
- 3) Apply a layer of lithium or general purpose bearing grease to surface of outer bearing cup (3). Insert the shaft (49) into the bearing carrier (2) (bearing cone down) and use a soft hammer to install the shaft seal (46) into the bearing carrier.

CAUTION: Output shaft is not retained at this point.

Unit Reassembly Procedure

(Refer to exploded drawing on Page 7)

- 1) Invert this assembly so it is standing on the shaft (on the press table).
- 2) Install secondary carrier assembly (6) onto bearing carrier (2) as follows.
 - a) Set carrier assembly down onto output shaft (49) spline.
 - b) Rotate carrier by hand until you are certain carrier spline has started cleanly and squarely onto shaft spline. View down through top of secondary carrier assembly through counter-bored holes in retainer plate (13).
 - c) Counter-bored holes in retaining plate should be centered between planet gears and must line-up with holes in the shaft. Slowly press secondary carrier assembly down tightly against the output shaft (49).
- 4) Install cap screws (15) and tighten to a torque of 120 ft-lbs if dry, 90 ft-lbs if lubed.
- 5) Install a new o-ring (44) on the bearing carrier (2).
- 6) Referring to scribe marks for proper orientation, install the secondary ring gear (4) by rotating until ring gear teeth line up with planet gears.
- 7) Check to be sure retaining ring (36) is installed on sun gear (12). Slide the sun gear into the secondary planet carrier.
- 8) Install the primary carrier (7) by rotating until spline lines up with sun gear. It may be easier to install the sun gear (12) into the bottom of the primary carrier and then install primary carrier.
- 9) **Timing Procedure:** There are timing marks on each of the three cluster gears (11). These marks should be aligned so that each points toward the center of the primary planet carrier. See diagram below:

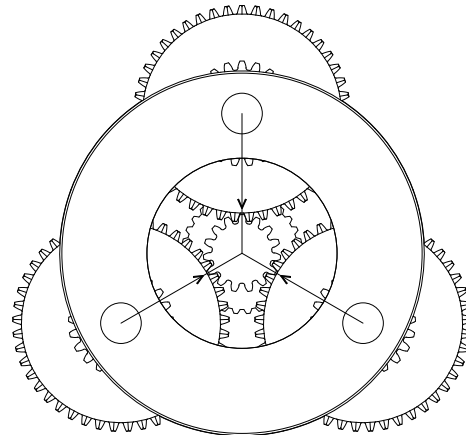

- 10) While keeping the timing marks aligned, slide the input gear **(14)** into the primary planet carrier.
- 11) Install a new o-ring **(44)** in the secondary ring gear **(1)**. Position the top case **(1)** with the proper orientation to scribed line on outside of unit and hold in position with two of the bolts placed in holes 180° apart.
- 12) Twist the input gear **(14)** to allow the top case **(1)** to drop down into place. Remove the two bolts used in Step 11.
- 13) Install o-ring **(43)** onto the hydraulic motor **(50)**.
- 14) Attach hydraulic motor **(50)** to mounting pad on top case **(1)** with two cap screws **(31)** and lock washers **(40)**. Tighten to a torque of 150 ft-lbs, dry (110 ft-lbs, wet).
- 15) Line up scribe mark on bail assembly **(20)** with scribe mark on top case **(1)** and place bail over hydraulic motor **(50)**. Install twelve cap screws **(29)** with hex-flange nuts **(34)** and torque to 30 ft-lbs.
- 16) Fill to proper level with EP 80/90 gear oil, as specified on Page 2.

THE AUGER DRIVE IS NOW READY TO USE

Exploded View Drawing



MODELS S77BA. S77BC & S77BD (SINGLE SPEED)

EFFECTIVE:
FROM S/N 31296 1-29-02
TO: CURRENT

ITEM	QTY	DESCRIPTION	S77BA	S77BC	S77BD
1	1	TOP CASE	72-004-3154	72-004-3154	72-004-3154
2	1	BEARING CARRIER	72-004-1102	72-004-1102	72-004-1102
3	1	BRG CUP - LOWER SHAFT CUP	01-103-0080	01-103-0080	01-103-0080
4	1	RING GEAR, SEC.	71-004-0042	71-004-0042	71-004-0042
5	1	RING GEAR, PRI.	71-004-0142	71-004-0142	71-004-0142
6	1	PLANET CARRIER, SEC.	71-004-2332	71-004-2332	71-004-2332
7	1	PLANET CARRIER, PRI.	71-004-0113	71-004-0433	71-004-0433
8	3	PLANET PIN, SEC.	71-004-0081	71-004-0081	71-004-0081
9	3	PLANET PIN, PRI.	71-004-0121	71-004-0121	71-004-0121
10	3	PLANET GEAR, SEC.	71-004-0092	71-004-0092	71-004-0092
11	3	CLUSTER GEAR, PRI.	71-004-0132	71-004-0412	72-004-0182
12	1	SUN GEAR, SEC.	71-004-0102	71-004-0102	71-004-0102
13	1	PLATE-BRG RETAINER	71-004-2322	71-004-2322	71-004-2322
14	1	INPUT GEAR	72-004-0132	72-004-0122	72-004-0082
15	3	SOCKET-HD CAPSCREW	01-150-1480	01-150-1480	01-150-1480
17	6	WASHER, PRI.	71-004-0861	71-004-0861	71-004-0861
18	6	WASHER, SEC.	71-004-0871	71-004-0871	71-004-0871
20	1	BAIL ASSY STD. 1.5 DIA BOSS	S71-005-0932	S71-005-0932	S71-005-0932
		BAIL ASSY BACKHOE 1.5 DIA BOSS	S72-005-3482	S72-005-3482	S72-005-3482
21	1	BRG CONE - UPPER SHAFT CONE	01-102-0100	01-102-0100	01-102-0100
23	6	BRG - PRI. PLANET	01-105-0010	01-105-0010	01-105-0010
24	3	BRG - SEC. PLANET	01-105-0020	01-105-0020	01-105-0020
25	1	BRG CONE - LOWER SHAFT CONE	01-102-0090	01-102-0090	01-102-0090
29	12	HEX CAP SCREW 3/8 - 16	01-150-0020	01-150-0020	01-150-0020
30	1	BRG CUP - UPPER SHAFT CUP	01-103-0090	01-103-0090	01-103-0090
31	2	HEX CAP SCREW 5/8-11 X 1-1/2	01-150-0110	01-150-0110	01-150-0110
32	8	S.H.C.S. 3/8-16	01-150-0520	01-150-0520	01-150-0520
33	6	ROLL PIN 3/16	01-153-0020	01-153-0020	01-153-0020
34	12	HEX. FLANGE NUT, 3/8-16	01-158-0360	01-158-0360	01-158-0360
36	1	RETAINING RING	01-160-0030	01-160-0030	01-160-0030
40	2	LOCKWASHER, 5/8	01-166-0040	01-166-0040	01-166-0040
41	2	PIPE PLUG, 1/2 NPT	01-207-0010	01-207-0010	01-207-0010
43	1	O-RING,	01-402-0010	01-402-0010	01-402-0010
44	2	O-RING,	01-402-0020	01-402-0020	01-402-0020
46	1	OIL SEAL	01-405-0540	01-405-0540	01-405-0540
47	2	DOWEL PIN	01-152-0070	01-152-0070	01-152-0070
49	1	OUTPUT SHAFT 2-1/2" HEX (STEEL)	71-004-4022	71-004-4022	71-004-4022
		OUTPUT SHAFT 2-5/8" HEX (STEEL)	71-004-4032	71-004-4032	71-004-4032
50	1	HYDRAULIC MOTOR	S01-304-0590	S01-304-0590	S01-304-0590

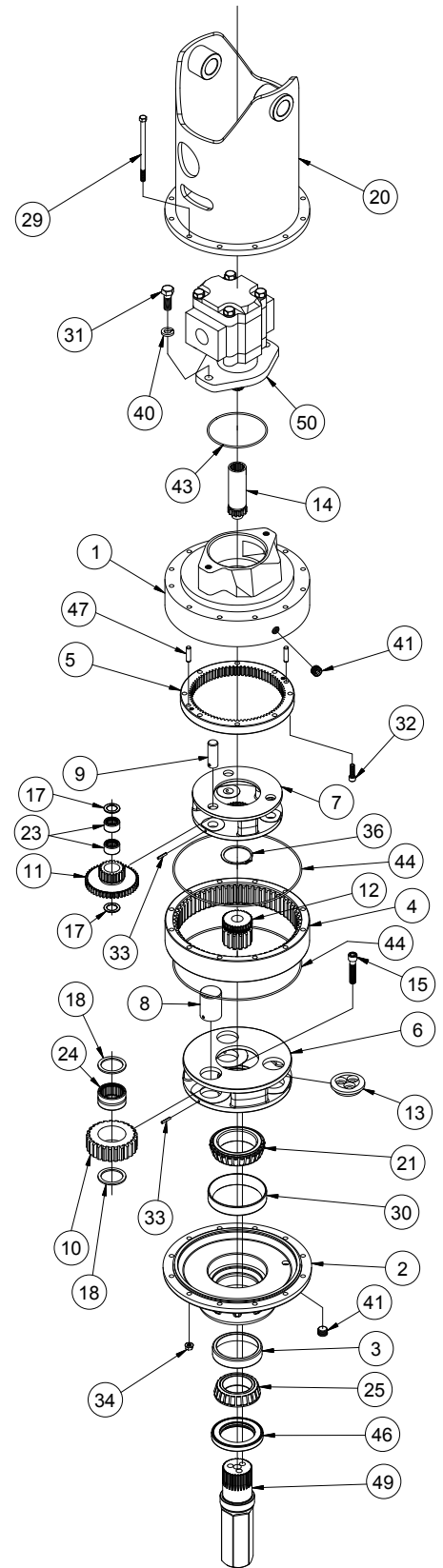

SEAL KIT P/N 76-016-2011
INCLUDES ITEMS 43,44 AND 46
MOTOR P/N PER CUSTOMER SPEC

XS77P-BA DATE: 11-17-05