

ESKRIDGE

D440 DOUBLE PLANETARY DIGGER DRIVE SERVICE AND REPAIR MANUAL

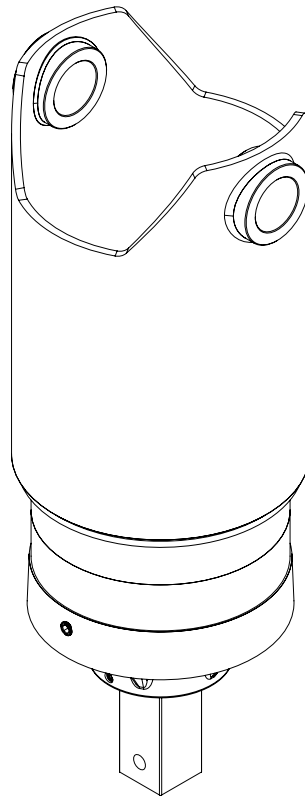

Example Part Number

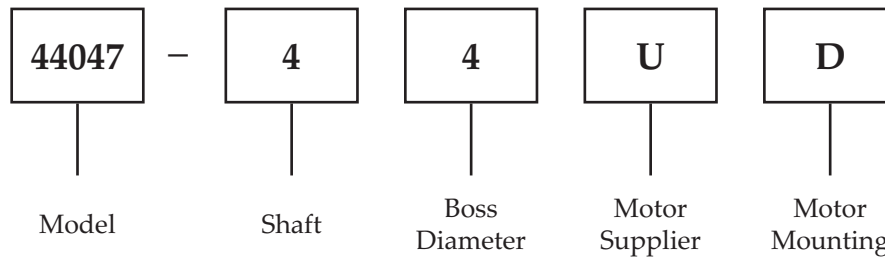

THIS SERVICE MANUAL IS EFFECTIVE
FROM:..... S/N , 70000 MAY 2006
TO:..... CURRENT
REF: SMD440LD2-AA

D440 DIGGER DRIVE SERVICE MANUAL

DOUBLE STAGE PLANETARY DIGGER DRIVE

This manual will assist in disassembly and assembly of major components for all Model 440 Planetary Digger Drives, including single and double planetary models. Item numbers, indicated in parentheses throughout this manual, refer to the Eskridge Model 440 exploded parts breakdown drawings. Individual customer specifications (mounting case, output shaft, brake assembly, etc.) may vary from exploded drawing and standard part numbers shown. If applicable, refer to customer drawing for details.

LUBRICATION & MAINTENANCE

Change the oil after the first 50 hours of operation. Oil should be changed at 500 hour intervals thereafter. Use a GL-5 grade EP 80/90 gear oil (EP = "Extreme Pressure"). The gear drive should be partially disassembled to inspect gears and bearings at 1000 hour intervals.

For shaft-up operation, the output bearing will not run in oil and must be grease lubricated. Use a lithium based or general purpose bearing grease sparingly every 50 operating hours or at regular maintenance intervals. Over-greasing the output bearing tends to fill the housing with grease and thicken the oil.

<u>Operating Position</u>	<u>Oil Capacity</u>	<u>Oil Level</u>
Vertical Shaft (Pinion Down)	2.6 gal / 10.0 liters	To midway on upper/primary gear set
Horizontal Shaft	2.1 gal / 7.9 liters	To horizontal centerline of gear drive



WARNING: While working on this equipment, use safe lifting procedures, wear adequate clothing and wear hearing, eye and respiratory protection.

CONTENTS

Example Part Number	1
Lubrication & Maintenance.....	2
Unit Disassembly Procedure.....	3
Primary Planet Carrier Subassembly	4
Secondary Carrier Subassembly	5
Base Subassembly.....	6
Unit Assembly.....	7
Exploded View Drawing	8
Eskridge Product Warranty	9
Warranty Return Policy	9
Eskridge Product Line	10

Unit Disassembly Procedure

- 1) Scribe a diagonal line across the outside of the unit from the bail **(3)** to the base **(1)** before disassembly to aid in the proper positioning of pieces during reassembly.
- 2) Remove magnetic drain plugs **(35)** and drain oil from unit. The oil will drain out faster and more completely if warm.
- 3) Remove the twenty hex-head capscrews **(32)** and lockwashers **(33)**.
- 4) Remove the bail assembly **(3)**, cover **(4)**, thrust bearing set **(21, 22)**, and input gear **(11)**. Inspect o-ring **(31)**; discard if damaged or deformed.
- 5) Lift the primary planet carrier assembly out of the unit **(includes Items 7, 9, 12, 13, 15, 16, 17, 18 & 20)**.
- 6) Remove the primary ring gear **(5)**. Inspect second O-ring **(31)**; as before, discard if damaged.
- 7) Using a screwdriver, seal pick or similar tool remove the retaining ring **(19)**, which retains the secondary planet carrier to the output shaft. The retainer can be left in the carrier but must be removed from the groove.
- 8) With a suitable lifting apparatus and a hoist, lift the secondary planetary assembly out of the unit **(includes Items 8, 10, 12, 15, 16, 17, 19 & 20)**.
- 9) Remove secondary ring gear **(6)**. Inspect third O-ring **(31)**; as before, discard if damaged or deformed.
- 10) The unit is now disassembled into groups of parts. The area(s) requiring repair should be identified by thorough inspection of the individual components after they have been cleaned and dried.

Primary Planet Carrier Subassembly

(Items 7, 9, 12, 13, 15, 16, 17, 18 & 20)

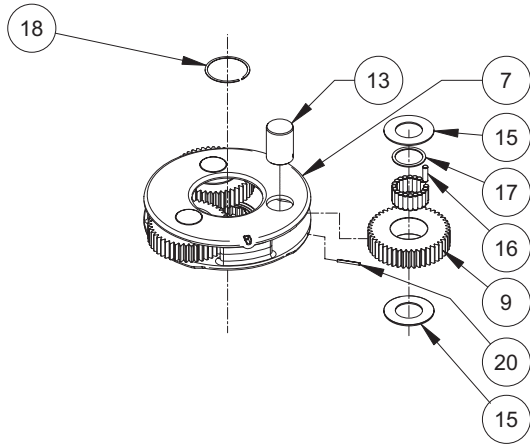

- d) Place spacer washer (17) onto planet shaft.
 - e) Place a washer (15) over the gear (9) onto the shaft (13).
 - f) Carefully slide the assembly off the table, holding the lower planet washer (13) and planet gear (7).
 - g) Slide the planet shaft (13) out of the assembly and slide the assembly into the carrier.
 - h) Align the planet gear/bearing assembly inside the carrier and install the planet shaft through the entire assembly.
- 5) Planet shafts (13) should be installed with the chamfered end of the 3/16 inch hole towards the outside diameter of the carrier (7); this will aid in alignment of holes while inserting roll pins (20).
 - 6) Drive roll pin (20) into the carrier hole and into the planet shaft to retain the parts. Repeat for remaining planet gears.

Disassembly

Rotate planet gears (9) to check for abnormal noise or roughness in bearings (16). If further inspection or replacement is required, proceed as follows.

- 1) Use a small screwdriver, seal pick or similar tool to remove the retaining ring (18) from sun. Leave retaining ring in carrier, but out of groove, and slide sun (12) out of carrier (7).
- 2) Drive roll pins (20) completely into the planet shafts (13).
- 3) Slide planet shafts (13) out of carrier (7).
- 4) Remove planet gears (9), washers (15) and rollers (16) from carrier (7).
- 5) Inspect the planet gear (9), bearing bore and planet shaft (13) and rollers (16). Check for spalling, bruising or other damage. Replace components as necessary; rollers should be replaced only as a set of 20.
- 6) Remove roll pins (20) from primary planet shafts (13) using a 3/16 inch pin punch.

Reassembly

- 1) Rebuild primary planet carrier assembly in reverse order using any needed new parts.
- 2) Insert the sun gear (12) in the splines of the carrier (7).
- 3) Install the retaining ring (18) into the corresponding groove of the sun gear (12).
- 4) Install rollers in gear as follows:
 - a) Set planet washer (15) on work table with planet gear (7) on top of it. Center the planet washer to the planet gear as closely as possible.
 - b) Center the planet shaft (13) in the planet gear (9) bearing bore.
 - c) Begin placing rollers (16) around the shaft (13). There should be clearance for the last roller to slide in. Be sure to install 20 rollers in each planet gear (9).

Secondary Carrier Subassembly

(Items 8, 10, 14, 15, 16, 17, 19 & 20)

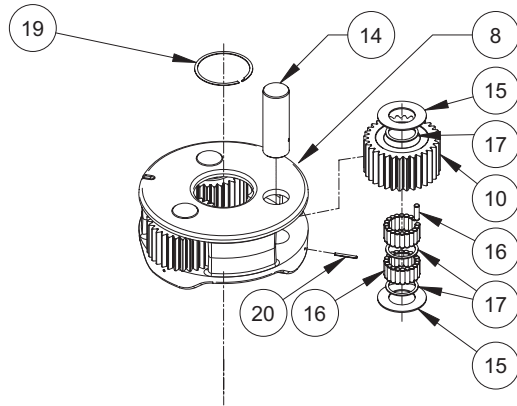

- g) Slide a spacer (17) over the second row of rollers (16).
 - h) Place a washer (15) over the gear (10) onto the shaft (14).
 - i) Carefully slide the assembly off the table, holding the lower planet washer (15) and planet gear (10).
 - j) Slide the planet shaft (14) out of the assembly and slide the assembly into the carrier (8).
 - k) Align the planet gear/bearing assembly inside the carrier and install the planet shaft through the entire assembly.
- 4) Planet shafts (14) should be installed with the chamfered end of the 3/16 inch hole towards the outside diameter of the carrier (8). This will aid in alignment of holes while inserting roll pins (20).
 - 5) Drive roll pin (20) through the carrier hole and into the planet shaft to retain the parts. Repeat for the other planet gears.

Disassembly

Rotate planet gears (10) to check for abnormal noise or roughness in bearings (16). If further inspection or replacement is required, proceed as follows.

- 1) Drive roll pins (20) completely into the planet shafts (14).
- 2) Slide planet shafts (14) out of carrier (8).
- 3) Remove planet gears (10), washers (15), spacers (17) and rollers (16) from carrier (8).
- 4) Inspect the planet gear (10), bearing bore and planet shaft (14) and rollers (16). Check for spalling, bruising or other damage. Replace components as necessary; rollers should be replaced only as a set of 40 (2 rows of 20).
- 5) Remove roll pins (20) from secondary planet shafts (14) using a 3/16 inch pin punch.

Reassembly

- 1) Rebuild secondary planet carrier assembly in reverse order using any needed new parts.
- 2) Place the spiral-wound retaining ring (19), with the depression positioned at the center of the carrier (8) in preparation for installation onto the output shaft (2).
- 3) Install rollers in gear as follows:
 - a) Set planet washer (15) on work table with planet gear (10) on top of it. Center the planet washer and the planet gear as closely as possible.
 - b) Slide a spacer (17) over the planet shaft.
 - c) Center the planet shaft (14) in the planet gear (10) bearing bore.
 - d) Begin placing rollers (16) around the shaft (14). There should be clearance for the last roller to slide in. Be sure to install 20 rollers per row in the planet gear (10).
 - e) Slide a spacer (17) over the first row of rollers (16).
 - f) Place a second row of rollers (16) around the planet shaft (14) as before.

Base Subassembly

(Items 1, 2, 23, 24, 25, 26, 27, 28, 29, 30, 35 & 36)

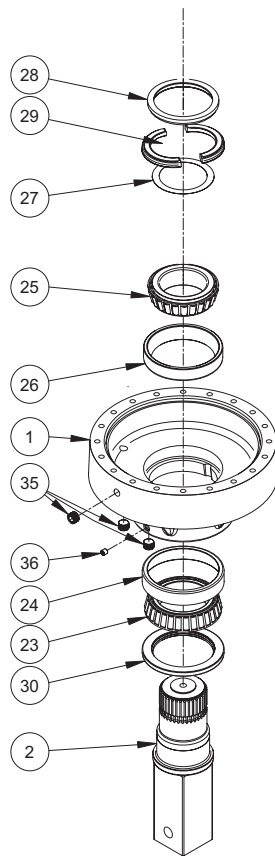

Disassembly

- 1) Remove the lock ring (28) using a heel bar or puller; if using a heel bar, be sure not to pry against the cage of the inner output shaft bearing (25). Remove the split ring segments (29) and shims (27).

Caution: Since it is no longer retained, care should be taken to avoid personal injury. Care should also be taken not to damage output shaft when it is pressed through base.

Output Shaft Removal

Note: Removing the shaft from the base assembly damages the shaft seal and the seal will need to be replaced.

- 1) Base (1) should be set pinion side down, as shown, on a plate or table. Press output shaft out bottom of base by applying a load to top end (internal end) of shaft until it passes through inner shaft bearing cone (25).
- 2) A gear puller may be used to remove the outer bearing cone (23) from the shaft (2). If reusing old bearing cone, do not pull on or damage roller cage. Remove the shaft seal (30) for inspection or replacement.
- 3) Lubricate inner lip of new shaft seal (30) and slide it onto the shaft (2) until it fits snugly over the shaft seal diameter with the open side toward the inside of the gear drive.

Note: Press bearing cone onto output shaft by pressing on inner race only. DO NOT press on roller cage, as it may damage bearing.

- 4) Inspect inner and outer bearing cups (26 & 24). If cups are damaged, drive them out using a brass drift and utilizing the bearing knock-out notches in the base (1)

Reassembly

- 1) Clean all foreign material from magnetic oil plugs (35) located in the base (1).
- 2) Place base (1) (output side up, opposite shown) on the table.
- 3) Apply a layer of lithium or general purpose bearing grease to the roller contact surface of outer bearing cup (24).
- 4) Press outer bearing cone (23) (large end down as shown) onto the shaft until it seats against the shoulder.
- 5) Place the shaft (2) with the bearing (23) into the base (1).
- 6) Flip this assembly, resting the base (1) on the end of the output shaft (2).
- 7) Apply a layer of lithium or general purpose bearing grease to the roller contact surface of the inner cup (26). Press the inner bearing cone (25) (large end up as shown) onto the shaft (2) until it is seated against inner bearing cup (26).
- 8) Without the shaft seal (30) installed, the preload may result in a rolling torque that varies between 50 to 300 in-lb. The bearing preload should be tailored to your application; a low-speed application may require a high pre-load, high-speed applications usually benefit from low pre-load. Adding shims (27) will increase the pre-load on the bearing set. Determine your pre-load requirement and install shims to obtain this pre-load. Install the Load-N-Lock™ segments (29) over the shims (27) and into the groove in the shaft (2). Finally, install the lock ring (28) over the segments (29).

All subassembly service or repairs should be complete at this time. Continue to Unit Assembly to complete unit buildup.

Unit Assembly

- 1) When all subassemblies are complete, the unit is ready to be assembled.
- 2) Install the secondary carrier assembly onto the output shaft; align the splines of the carrier **(8)** with the splines of the shaft **(2)** and slide the carrier onto the shaft.
- 3) Install the retaining ring **(19)** onto the groove of the shaft **(2)**, using a spiraling motion.
- 4) Lubricate o-ring **(31)** and install on the pilot of the secondary ring gear **(6)**.

Caution: Hold ring gear by outside or use lifting device to prevent injury.

- 5) Align gear teeth of ring gear **(6)** with the gear teeth of the planet gears **(10)** and place on base. Now align mounting holes of ring gear with holes in base. Use the scribed line made during disassembly for reference.
- 6) Install the primary carrier assembly with the sun **(12)** into the secondary carrier.
- 7) Lubricate o-ring **(33)** and install on the pilot of the primary ring gear **(5)**.

Caution: Again, hold the ring gear by outside diameter or use lifting device to prevent injury.

- 8) Align gear teeth of ring gear with those of the planet gears and place on base. Align mounting holes of ring gear with holes in base. Use the scribed line made during disassembly for reference.
- 9) Install the input gear **(11)**.
- 10) Install the thrust bearing set **(21, 2 each; 22, 1 each)**.
- 11) Lubricate o-ring **(3)** and install on the pilot of the cover **(3)**.
- 12) Noting the scribed line made during disassembly, install the cover **(4)** and bail **(3)**.
- 13) Install and torque the 20 5/8-11 hex-head cap-screws **(32)** with lockwashers **(33)**. The torque for the cap-screws: **220 ft-lb dry, 170 ft-lb if the fasteners are lubricated**.
- 14) Ensure the unit spins freely by using a splined shaft to drive the input gear **(11)**.
- 15) Fill the unit to the proper level, as specified, with GL5 EP 80/90 gear oil after it is sealed with a brake and/or motor.

The gearbox is now ready to use.

Exploded View Drawing



MODEL 440LD2 DIGGER

ITEM	QTY	DESCRIPTION	PART NO.
1	1	BASE-"F" FLANGELESS	42-004-3022
2	1	SHAFT- 4 INCH SQUARE	42-004-4102
3	1	BAIL ASSEMBLY	42-005-0171
4	1	COVER (4 Bolt "E")	42-004-2032
5	1	RING GEAR - PRIMARY	42-004-1042
6	1	RING GEAR - SECONDARY	42-004-1032
7	1	CARRIER - PRIMARY	42-004-1282
8	1	CARRIER - SECONDARY	42-004-1392
9	3	PLANET GEAR - PRIMARY	42-004-1272
10	3	PLANET GEAR - SECONDARY	42-004-1242
11	1	INPUT GEAR (15T, 8/16 dp)	42-004-1412
12	1	SUN GEAR-SECONDARY	42-004-1252
13	3	PLANET SHAFT - PRIMARY	42-004-1342
14	3	PLANET SHAFT - SECONDARY	42-004-1332
15	12	PLANET THRUST WASHER	42-004-1362
16	180	PLANET ROLLER	01-106-0040
17	12	ROLLER SPACER WASHER	42-004-1352
18	1	SUN GEAR RETAINING RING	01-160-0690
19	1	CARRIER RETAINING RING	01-160-0680
20	6	ROLL PIN	01-153-0220
21	2	THRUST WASHER	01-112-0400
22	1	THRUST BEARING	01-112-0410
23	1	BEARING CONE (TIMKEN 67388)	01-102-0290
24	1	BEARING CUP (TIMKEN 67322)	01-103-0290
25	1	BEARING CONE (TIMKEN 71450)	01-102-0280
26	1	BEARING CUP (TIMKEN 71750)	01-103-0280
27	***	SHIM - OUTPUT SHAFT	42-004-1202
28	1	LOCK RING	42-004-1212
29	1	SPLIT RING (L-SEGMENT-425)	42-004-1222
30	1	OUTPUT SHAFT SEAL	01-405-0770
31	3	O-RING	01-402-0840
32	20	HEX CAP SCREW - 5/8-11 UNC - 9.5	01-150-1950
33	20	5/8" HELICAL SPRING LOCK WASHER	01-166-0040
34	2	HOLLOW HEX PLUG -12 SAE	01-208-0030
35	3	PIPE PLUG (3/4 NPT, MAGNETIC)	01-207-0100
36	1	PIPE PLUG (1/4 NPT)	01-207-0020

*** QUANTITY OF SHIMS DETERMINED BY BEARING PRELOAD REQUIRED

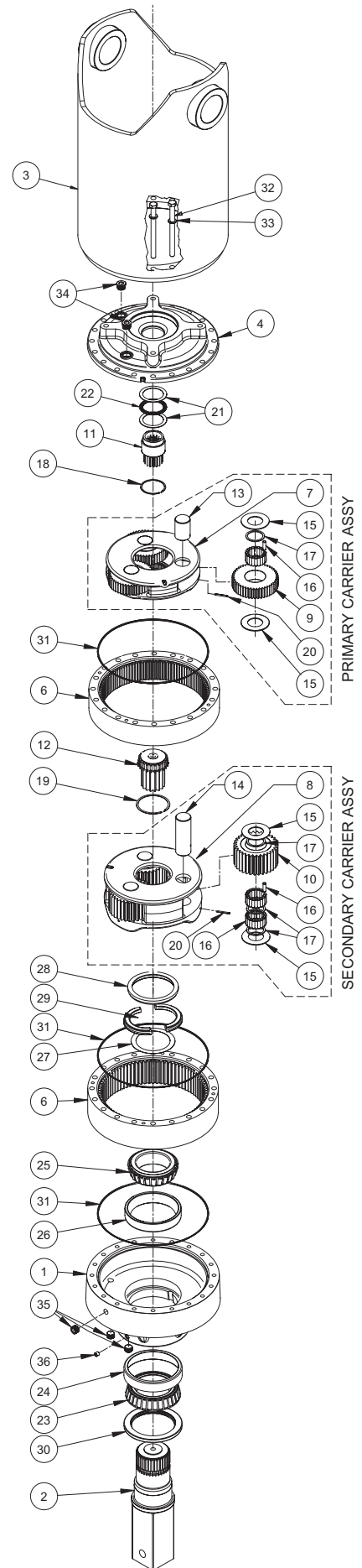

Eskridge Product Warranty

ESKRIDGE, INC. ("Eskridge") warrants to its original purchaser ("Customer") that new component parts/units ("Units") sold by Eskridge will be free of defects in material and workmanship and will conform to standard specifications set forth in Eskridge sales literature current at the time of sale or to any custom specifications acknowledged by written Customer approval of drawings, SUBJECT TO THE FOLLOWING QUALIFICATIONS AND LIMITATIONS:

1. Prior to placing Units in service, the Customer shall provide proper storage such that foreign objects (e.g., rain or debris) cannot enter any Units via entry ports which are normally closed during operation.
2. The Customer must notify Eskridge in writing of any claim for breach of this warranty promptly after discovery of a defect. The warranty period shall commence when a unit is placed in service and shall expire upon the earlier of
 - a. the expiration of twelve (12) months from the date of Commencement of Service (as defined in Paragraph 4)
 - b. the completion of one thousand (1000) hours of service of the Units
 - c. the expiration of six (6) months after the expiration of any express warranty relating to the first item of machinery or equipment in which the Units are installed or on which it is mounted, or
 - d. the installation or mounting of the Units in or on an item of machinery or equipment other than the first such item in which the Units are installed or on which the Units are mounted.
3. Units shall be deemed to have been placed in service (the "Commencement of Service") at the time the machinery or equipment manufactured or assembled by the Customer and in which the Units are installed or on which the Units are mounted is delivered to the Customer's dealer or the original end-user, which ever receives such machinery or equipment first.
4. This warranty shall not apply with respect to Units which, upon inspection by Eskridge, show signs of disassembly, rework, modifications, lack of lubrication or improper installation, mounting, use or maintenance.
5. Eskridge makes no warranty in respect to hydraulic motors mounted on any Units. Failure of any such motor will be referred to the motor manufacturer.
6. Claims under this warranty will be satisfied only by repair of any defect(s) or, if repair is determined by Eskridge in its sole, absolute and uncontrolled discretion to be impossible or impractical, by replacement of the Units or any defective component thereof. No cash payment or credit will be made for defective materials, workmanship, labor or travel. IN NO EVENT SHALL ESKRIDGE BE LIABLE FOR INCIDENTAL OR CONSEQUENTIAL DAMAGES OF ANY KIND OR NATURE, FOR WHICH DAMAGES ARE HEREBY EXPRESSLY DISCLAIMED.
7. From time to time, Eskridge may make design changes in the component Units manufactured by it without incorporating such changes in the component Units previously shipped. Such design changes shall not constitute an admission by Eskridge of any defects or problems in the design of previously manufactured component Units.
8. All freight charges on Units returned for warranty service are the responsibility of the Customer.

Warranty Return Policy

1. Any part/Unit(s) returned to Eskridge must be authorized by Eskridge with an assigned return (CSR) number.
2. All Units shall be returned freight prepaid.
3. Any Units qualifying for warranty will be repaired with new parts free of charge (except for freight charges to Eskridge as provided above).
4. If Units are found to be operable, you have two options:
 - a. The Units can be returned to you with a service charge for inspection, cleaning, and routine replacement of all rubber components and any other Units that show wear;
 - b. We can dispose of the Unit(s) at the factory if you do not wish it to be returned.

NOTE: Any order of Units by customer shall only be accepted by Eskridge subject to the terms stated herein. Any purchase order forms used by Customer (to accept this offer to sell) which contain terms contrary to, different from, or in addition to the terms herein shall be without effect, and such terms shall constitute material alteration of the offer contained herein under K.S.A 84-2-207 (2)(b), and shall not become part of the contract regarding the sale of the Units.

The foregoing warranty is the sole warranty made by Eskridge with respect to any Units and is in lieu of any and all other warranties, expressed or implied. There are no warranties which extend beyond the description on the face hereof without limiting the generality of the foregoing, Eskridge expressly disclaims any implied warranty of merchantability or fitness for any particular purpose, regardless of any knowledge Eskridge may have of any particular use or application intended by the purchaser. The suitability or fitness of the Units for the customer's intended use, application or purpose and the proper method of installation or mounting must be determined by the customer.

ESKRIDGE PRODUCT LINE

Planetary Gear Drives

<u>Series</u>	<u>Features</u>	<u>Torque Rating (in-lb)</u> <i>Maximum Intermittent</i>
20	Shaft Output	20,000
28	Shaft Output	50,000
50	Shaft or Spindle Output	50,000
65	Shaft Output	65,000
105	Shaft Output	105,000
130/133	Shaft or Spindle Output	130,000
150	Shaft Output	150,000
250/252/254	Shaft or Spindle Output	250,000
440	Shaft or Spindle Output, Wheel Drive	440,000
600	Shaft or Spindle Output, Wheel Drive	600,000
1000	Shaft or Spindle Output, Wheel Drive	1,000,000

Multiple Disc Brakes

<u>Series</u>	<u>Features</u>	<u>Torque Rating (in-lb)</u>
10" <i>(Available on Series 65, 105 & 130 Gear Drives)</i>	SAE A Input	to 4,800
90B	SAE B Output	to 4,800
90BA	SAE B Output, Adjustable Torque	to 4,800
92B	SAE B Output, Low Profile	to 2,100
93 (931 or 921)	For Nichols Motors	to 6,200
95C	SAE C Output	to 12,000
98D	SAE D Output	to 25,000

Planetary Auger, Anchor & Digger Drives

<u>Series</u>	<u>Features</u>	<u>Torque Rating (ft-lb)</u> <i>Maximum Intermittent</i>
75	38 & 51, 2-Speed	14,000—20,000
76	BA & BC, 2-Speed	8,000—12,5000
77	BA, BC & BD	6,000—12,5000
78	35 & 48, 2-Speed	9,000—12,500
D50	1500, 2500 & 5000	1,500—5,000
D440	D440	35,000
D600	D600	50,000
D1000	D1000	83,000

