



MODEL D1400 PLANETARY DIGGER DRIVE SERVICE MANUAL



WARNING: While working on this equipment, use safe lifting procedures, wear adequate clothing and wear hearing, eye and respiratory protection.

THIS SERVICE MANUAL IS EFFECTIVE:
S/N: 74362 TO CURRENT
DATE: 07/01/2007 TO CURRENT
VERSION:.... SMD1400-AA

NOTE: Individual customer specifications (mounting case, output shaft, brake assembly, etc.) may vary from exploded drawing and standard part numbers shown. If applicable, refer to customer drawing for details.

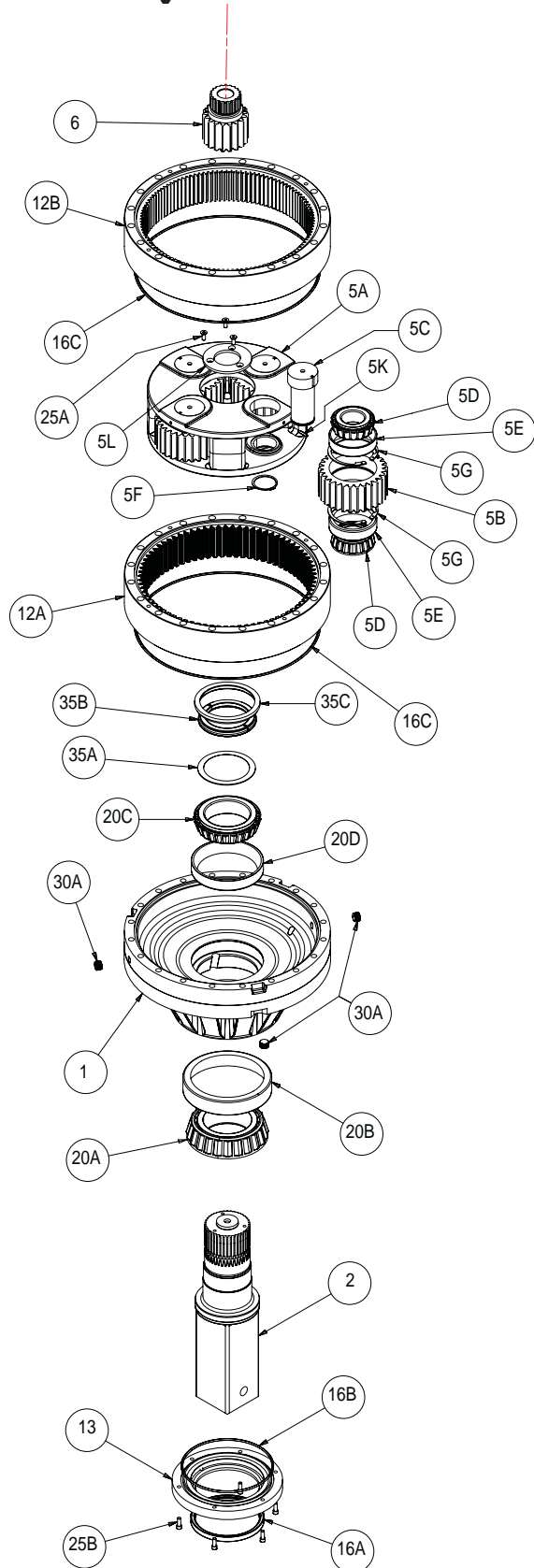
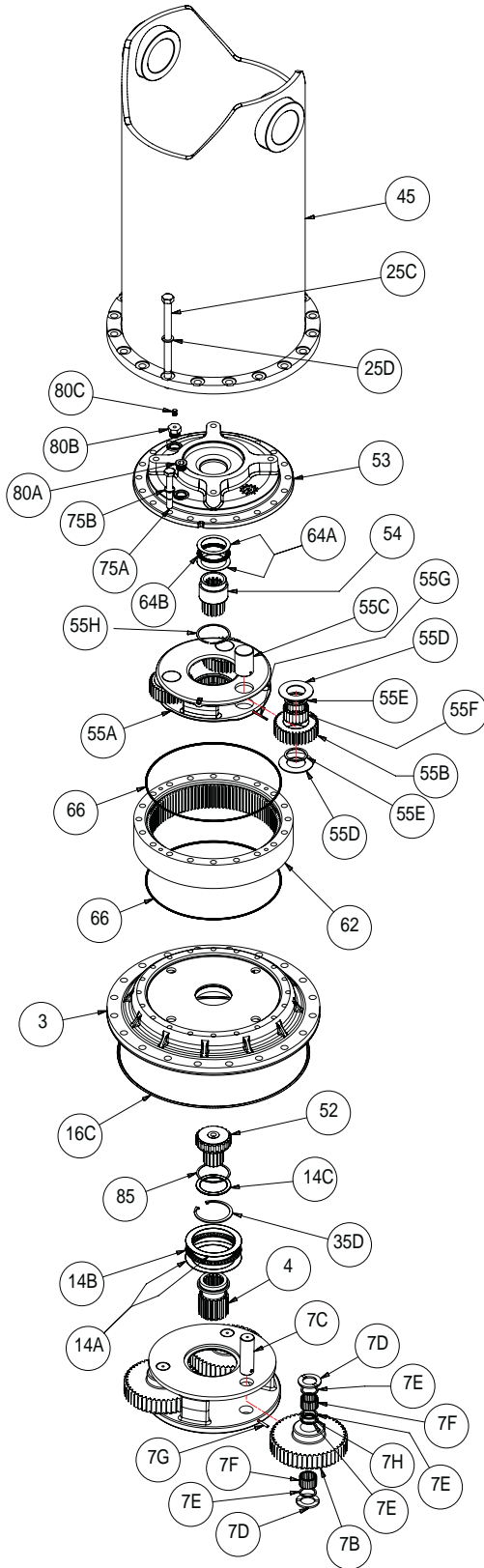

XD1400-AA,
Page 1 of 2
Effective date 07/01/2007
Effective serial # 74362

D1400 Ratio breakdown						
Unit	104	155	201	163	243	314
Stg I	3.95	5.87	7.59	3.95	5.87	7.59
Stg II/Primary	4.96	4.96	4.96	7.76	7.76	7.76
Stg III/Secondary	5.33	5.33	5.33	5.33	5.33	5.33

MODEL D1400 DIGGER			26.48:1 4.96:1 5.33:1	41.41:1 7.76:1 5.33:1		
Item #	QTY.	Description	Part Number	Part Number		
1	1	BASE; CODE F - FLANGELESS	60-004-3014			
2	1	OUTPUT SHAFT - 5-1/4 SQUARE DRIVE	60-004-4222L			
3	1	COVER #1 - 440 THIRD-STAGE	60-004-1934			
4	1	INPUT GEAR #1; CODE 8 (16T, 8/16 SPLINE)	60-004-1402	60-004-1492		
5	1	SEC CARR ASSY-5.33:1(1400)	60-005-2133			
5A	1	CARRIER SEC; 4-PLANET	60-004-1774			
5B	4	PLANET GEAR; SEC	60-004-1232			
5C	4	PLANET SHAFT; SEC	60-004-1262			
5D	8	CONE; SEC. PLNT H414242	01-102-0210			
5E	8	CUP; SEC.PLNT H414210	01-103-0210			
5F	4	RETAINING RING; PLANET SHAFT #3100-262	01-160-0490			
5G	8	RETAINING RING; PLANET BORE #3000-X537	01-160-0500			
5H	8	WASHER; SEC	60-004-1291			
5J	8	SHIM; SEC. PLNT	60-004-1321			
5K	4	ROLL PIN; 1/4 x 1 3/8	01-153-0150			
5L	1	PLATE; SEC CARRIER RETAINER	60-004-1352			
6	1	SUN GEAR -SECONDARY	60-004-1792			
7	1	PRIMARY CARRIER ASSY-1400	60-005-2113	60-005-2123		
7A	1	CARRIER; PRIMARY	60-004-1372	60-004-1722		
7B	3	PLANET GEAR; PRIMARY	60-004-1862	60-004-1872		
7C	3	PLANET SHAFT; PRIMARY	60-004-1272			
7D	6	THRUST WASHER; PRIMARY PLANET	60-004-1881			
7E	12	SPACER WASHER; PRI ROLLER; 4 PER SHAFT	60-004-1891			
7F	168	LOOSE ROLLER; 2 X 28 PER SHAFT 3/16 X 1.12	01-106-0050			
7G	3	ROLL PIN; 1/4 x 1 3/8	01-153-0150			
7H	3	RETAINING RING; PLANET BORE #5008-187	01-160-0750			
12A	1	RING GEAR; SEC.	60-004-1243			
12B	1	RING GEAR; SIMPLE PRI	60-004-1193			
13	1	SEAL CARRIER	60-004-1922			
14A	2	THRUST RACE; PRI CARR AS120155	01-112-0350			
14B	1	THRUST BRG; PRI CARR AXK120155	01-112-0340			
14C	1	THRUST RACE; INPUT GEAR TRD-4860	01-112-0060			
16A	1	SEAL; OUTPUT SHAFT #416044	01-405-0810			
16B	1	O-RING; SEAL CARRIER #2-377	01-402-0670			
16C	3	O-RING; RING GEAR #2-389	01-402-0660			
20A	1	BRG CONE; OUTER #99550	01-102-0190			
20B	1	BRG CUP; OUTER #99100	01-103-0190			
20C	1	BRG CONE; INNER #799A	01-102-0220			
20D	1	BRG CUP; INNER #792	01-103-0220			
25A	3	FLAT HD SOC C.S.; SEC CARR RET. (3/8-24X1 GR-8)	01-150-1590			
25B	6	SHCS; (3/8-16 X 1 GR 8); SEAL CARRIER	01-150-1110			
25C	20	HHCS (3/4-10 x 11.5 GRD 8)	01-150-1720			
25D	20	HARDWASHER; 3/4; 1.25 O.D.	01-166-0350			
30	4	PIPE PLUG (3/4 NPT MAGNETIC)	01-207-0100			
35A	2	SHIM; OUTPUT SHAFT	60-004-1311			
35B	1	SPLIT RING (L-SEGMENT)	60-004-1482			
35C	1	LOCK RING	60-004-1472			
35D	1	RETAINING RING; INPUT HOI #5008-400	01-160-0510			
45	1	BAIL ASSEMBLY; 4.0 BOSSES	60-005-2153			
MODEL 440 CORE UNIT:			1400-440-4	1400-440-5	1400-440-7	
MODEL 440 THIRD STAGE			3.95	5.87	7.59	
52	1	SPLINED ADAPTOR SHAFT	60-004-1902			
53	1	COVER #2	SAE 'C' 2 BOLT AND 4 BOLT	42-004-2012		
		SAE 'D' 4 BOLT	42-004-2022			
		SAE 'E' 4 BOLT	42-004-2032			
54	1	INPUT GEAR #2	CODE 9 - 13 TOOTH, 8/16	42-004-1152	42-004-1162	42-004-1172
		CODE 5 - 15 TOOTH, 8/16	42-004-1522	42-004-1532	42-004-1412	
		CODE 8 - 16 TOOTH, 8/16	42-004-1542	42-004-1552	PNNYA	
55	1	CARRIER ASSY - THIRD STAGE	42-005-0101	42-005-0111	42-005-0121	
55A	1	CARRIER; 3RD STAGE	42-004-1062	42-004-1072	42-004-1282	
55B	3	PLANET GEAR; 3RD STAGE	42-004-1102	42-004-1112	42-004-1272	
55C	3	PLANET SHAFT; 3RD STAGE		42-004-1342		
55D	6	THRUST WASHER; 3RD STAGE PLANET		42-004-1362		
55E	6	SPACER WASHER; 3RD STAGE ROLLER		42-004-1352		
55F	60	LOOSE ROLLER; 20 PER SHAFT 3/8 X 1.32		01-106-0040		
55G	3	ROLL PIN; 3/16 X 1-3/4		01-153-0220		
55H	1	RETAINING RING; ADAPTOR SHAFT #VS-337		01-160-0690		
62	1	RING GEAR; PRIMARY		42-004-1042		
64A	2	THRUST WASHER TRB-4458		01-112-0400		
64B	1	THRUST BEARING NTA-4458		01-112-0410		
66	2	O-RING; RING GEAR #2-280		01-402-0840		
75A	20	HEX HEAD CAPSCREW (5/8-11 X 4.5 GR 8)		01-150-0870		
75B	20	LOCKWASHER 5/8		01-166-0040		
80A	1	PLUG; COVER #2 SAE #12		01-208-0030		
80B	1	ADAPTER SAE #12 X 1/8 NPT		01-201-0520		
80C	1	BREATHER 1/8 NPT		01-216-0100		
85	1	RETAINING RING; ADAPTOR SHAFT #VS-337		01-160-0690		

XD1400-AA

Page 2 of 2

Effective date 07/01/2007

Effective serial # 74362

LUBRICATION & MAINTENANCE

Using the chart below, determine an appropriate lubricant viscosity. Use only EP (extreme pressure) or API GL-5 designated lubricants. Change the lubricant after the first 50 hours of operation and at 500 hour intervals thereafter. The digger drive should be partially disassembled to inspect gears and bearings at 1000 hour intervals.

Recommended ambient and operating temperatures for conventional and synthetic gear lubricants

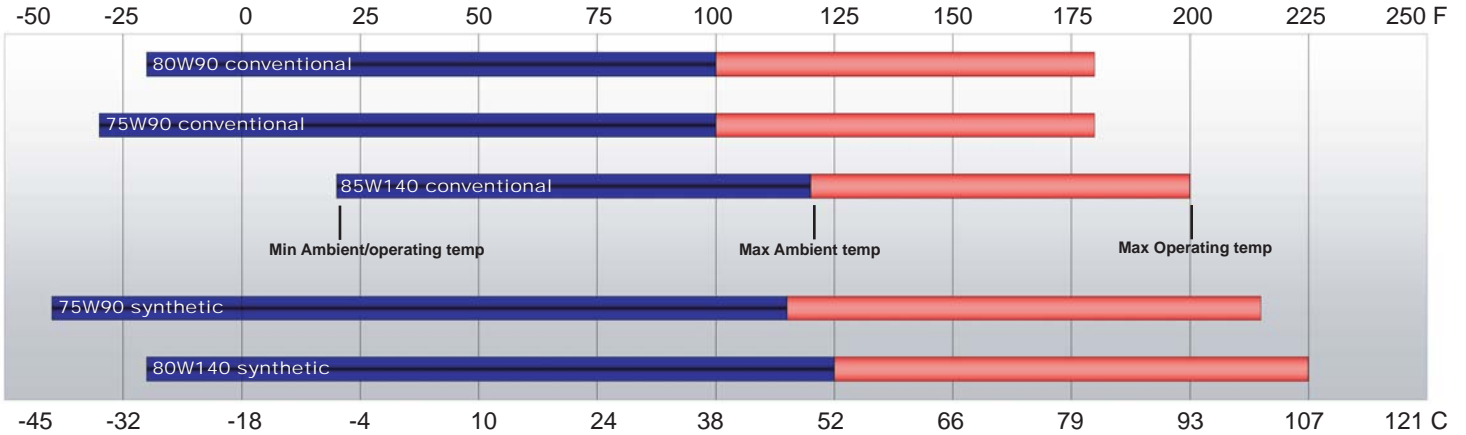

Note: Ambient temperature is the air temperature measured in the immediate vicinity of the gearbox. A Gearbox exposed to the direct rays of the sun or other radiant heat sources will operate at higher temperatures and therefore must be given special consideration. The max operating temp must not be exceeded under any circumstances, regardless of ambient temperature.

ESKRIDGE MODEL D1400 OIL CAPACITIES

Operating Position	Oil Capacity			Oil Level
	Single stage	Double stage	Triple stage	
Horizontal Shaft	-	18 qts / 17 Liters	-	To horizontal centerline of digger drive
Vertical Shaft (Pinion Up)	-	N/A	-	To side port on digger drive base
Vertical Shaft (Pinion Down)	-	31 qts / 29 Liters	-	To midway on upper/primary gear set

ESKRIDGE PART NUMBER INTERPRETATION

Note: All standard Eskridge Geardrives are issued a descriptive part number which includes information regarding the Model, means of shaft retention, base style, shaft style, input mounting, input shaft size, overall ratio and various available options. For a detailed breakdown of this information, please refer to Eskridge product specification sheets found at: <http://www.eskridgeinc.com/geardrives/gearprodspecs.html>

Unit Teardown

- 1) Scribe a diagonal line across the outside of the unit from the top cover (53) to the adapter cover (3), and to the base (1) before disassembly to aid in the proper positioning of pieces during reassembly.
- 2) Remove drain plugs (30) and drain oil from unit. The oil will drain out more quickly and completely if warm.
- 3) Remove the twenty 3/4-10 capscrews (25C) securing the bail (45) to the unit and remove bail. Once bail has been removed, re-install two capscrews to base assembly to secure the adapter cover (3) during Stage I disassembly.
- 4) Remove the twenty 5/8-11 capscrews (75B) securing the top cover (53) to the unit.
- 5) Remove the top cover (53), input thrust washer(s) , bearing(s) (64A, 64B), and Stage I input gear (54). Inspect cover o-ring (66); discard if damaged or deformed.
- 6) Lift the stage I planet carrier assembly (55) including shaft adapter (52) from the unit .
- 7) Remove Stage I ring gear (62), inspect o-ring (66) and replace if damaged or deformed.
- 8) Remove the two remaining 3/4-10 capscrews (25C) and lockwashers (25D) from the adapter cover.
- 9) Remove the ring adapter cover (3), thrust race (14C), Stage II sun gear (54) and thrust washers.(14A, 14B) from unit. Inspect cover o-ring (16C); discard if damaged or deformed
- 10) Lift the stage II planet carrier assembly (7) from the unit .
- 11) Remove the Stage III sun gear (6).
- 12) Remove the three 3/8-24 flat head capscrews (25A) securing the carrier retaining plate (5L) to the output shaft (2).
- 13) Remove remaining ring gears (12B, 12A) and Stage III carrier assembly (5). Inspect gear to gear and gear to base O-ring(s) (16C), discard and replace any damaged or deformed O-rings.
- 14) The unit is now disassembled into groups of parts. The area(s) requiring repair should be identified by thorough inspection of the individual components after they have been cleaned and dried.

Carrier Assembly Teardown

Rotate planet gears (55B Stg I, 7B Stg II, 5B, Stg III) to check for abnormal noise or roughness in bearings. If further inspection or replacement is required, proceed as follows.

- 1) Drive roll pins (55G Stg I, 7C Stg II) completely into the planet shafts or remove planet shaft retaining rings (5F Stg III)
- 2) Slide planet shafts (55C Stg I, 7C Stg II, 5C Stg III) out of carrier (55A Stg I, 7A Stg II, 5A Stg III).
- 3) Remove planet gears, washers (55D Stg I, 7D Stg II) and bearings (55E Stg I, 7F Stg II, 5D & 5E Stg III) from carrier.
- 4) Inspect the planet gear, bearing bore and planet shaft (55C Stg I, 7C Stg II, 5C Stg III) and bearings. Check for spalling,

bruising or other damage and replace components as necessary. *Note: When using loose (uncaged) roller bearings, all rollers in the corresponding planet gear should be replaced if any in the set are found to be defective*

- 5) Remove roll pins (55C Stg I, 7C Stg II) from planet shafts (55C Stg I, 7C Stg II) using a 3/16" (Stg I) or 1/4" (Stg II) pin punch.

Carrier Reassembly

- 1) Loose roller installation; if using bearing assemblies, replace bearings as needed and proceed to step 2:
 - a) Set planet washer (55D Stg I, 7D Stg II) on work table with planet gear (55B Stg I, 7B Stg II) on top of it. Center planet washer to planet gear as closely as possible.
 - b) Center planet shaft (55C Stg I, 7C Stg II) in planet gear bearing bore.
 - c) If used, place spacer washer (55E Stg I, 7E Stg II) onto planet shaft (refer to exploded view to confirm spacer positions).
 - d) Begin placing rollers (55F Stg I, 7F Stg II) around shaft (5C Stg I, 7C Stg II). There should be clearance for last roller to slide in. Be sure to install sixteen (Stg I) or twenty (Stg II) rollers in each bearing row.

(If using multiple rows of rollers, repeat steps C and D as necessary. Once complete, refer to exploded view to confirm that any spacer washers (55E Stg I, 7E Stg II) are appropriately positioned.)
 - e) Place a washer (55D Stg I, 7D Stg II) over gear and onto shaft.
 - f) Carefully slide assembly off of table, holding planet washers against planet gear.
 - g) Slide planet shaft out of the assembly and slip assembly into carrier.
 - h) Align planet gear & bearing assembly inside carrier and install planet shaft through entire assembly.

- 2) Planet shafts (55C Stg I, 7C Stg II, 5C Stg III) should be installed with chamfered end of roll pin hole (Stg I, II) or slot (Stg III) towards outside diameter of carrier.
- 3) Drive roll pin into the carrier hole (Stg I & II) and into planet shaft or replace planet shaft retaining rings (Stg III) to retain parts. Repeat for remaining planet gears.

Base Subassembly Teardown

- 1) Remove the seal carrier retaining screws (25B) and seal carrier (13) from unit. Inspect seal (16A) for signs of wear or damage and replace as necessary.
- 2) Remove the output shaft lock ring (35C) using a heel bar or puller; if using a heel bar, be sure not to pry against the cage of the inner output shaft bearing (20C). Remove the split ring segments (35B) and shims (35A).

Caution: Since the shaft is no longer positively retained, care should be taken to avoid injury. Care should also be

taken not to damage it while pressing through base.

- 3) Place base (1) exterior side down, on a plate or table. Press output shaft out bottom of base by applying a load to internal end of shaft until it passes through inner shaft bearing cone (20C).
- 4) A gear puller may be used to remove the outer bearing cone (20A) from the shaft (2). If reusing old bearing cone, do not pull on or damage roller cage.

Note: Press bearing cone onto output shaft by pressing on inner race only. DO NOT press on roller cage, as it may damage the bearing assembly.

- 5) Inspect inner and outer bearing cups (20D & 20B). If cups are damaged, drive them out using a brass drift and utilizing the bearing knock-out notches in the base (1)

Base Reassembly

- 1) Clean all foreign material from magnetic oil plugs located in base (1).
- 2) Place base exterior side up on work table.
- 3) Apply a layer of lithium or general purpose bearing grease to the roller contact surface of outer bearing cup (20B).
- 4) Press outer bearing cone (20A) onto the shaft until it seats against the shoulder.
- 5) Place the shaft (2) with the outer bearing cone into the base.
- 6) Flip shaft/base assembly, and apply lithium or general purpose bearing grease to roller contact surface of the inner cup (20D), then press inner bearing cone (20C) onto shaft until it seats against inner bearing cup.
- 7) Prior to installation of the shaft seal the pre-load may result in a rolling torque which varies between 200 to 300 in-lb. The bearing preload should be tailored to your application; a low-speed application may require a high pre-load, while high-speed applications usually benefit from low pre-load. Adding shims (35A) will increase the pre-load on the bearing set. Determine your pre-load requirement and install shims to obtain this pre-load.

Install the Load-N-Lock™ segments (35B) over the shims and into the shaft groove. Then, install the lock ring (35C) over the segments (35B).

- 8) Lubricate shaft seal and reinstall seal carrier.

All subassembly service or repairs should be complete at this time. Continue to Unit Assembly to complete buildup of unit.

Unit Reassembly

- 1) Install the Stage III carrier assembly onto the output shaft; align the splines of the carrier (5A) with the output shaft splines and slide the carrier onto the output shaft (2).
- 2) Install carrier retaining plate (5L) & secure using provided 3/8-24 Flathead capscrews (25A). If using retaining compound to assist in screw retention, apply only a small amount to internal threads. Use of excess thread retaining compound may cause screws to be irremovable once compound has cured.

- 3) Lubricate o-rings (16C) and install on the ring gear (12 Stg II, 12A Stg III) pilots.

Caution: Use lifting device to prevent injury when handling ring gears and other heavy components.

- 4) Align gear teeth of Stage III ring gear (12A) with planet gears (5B) and place on base, then align mounting holes of ring gear with holes in base. Use the scribed line made during disassembly for reference.
- 5) Install Stage II ring gear (12B) with lubricated o-ring in place. Align mounting holes of ring gear with holes in base, using the scribed line made during disassembly for reference.
- 6) Install Stage III sun gear (6), then Stage II carrier assembly (7), aligning gear teeth of ring gear with those of the planet gears and carrier splines aligned with those on the Stage III sun gear (6).
- 7) Install Stage II sun gear (4), and stage II carrier thrust-washers (14A, 14B).
- 8) Install o-ring (16C) to ring adapter cover (3) and install adapter cover to Stage II ring gear, aligning mounting holes of cover with those in ring gears. Use the scribed line made during disassembly for reference.
- 9) Install, but do not torque two of the 3/4-10 capscrews (25C) to retain adapter cover and ring gears during assembly of remainder of unit.
- 10) Install o-ring on Stage I ring gear (62) and install ring gear to adapter cover, aligning mounting holes of ring with those in the adapter cover. Use the scribed line made during disassembly for reference.
- 11) Install the Stage I carrier assembly with adapter shaft (52) into the Stage I ring gear (62).
- 12) Install the input gear (54) and thrust bearing set (64A, 64B) Refer to exploded view for details..
- 13) Noting the scribed line made during disassembly, (with lubricated o-ring in place) align and install the top cover (53).
- 14) Install and torque the twenty 5/8-11 hex-head capscrews (75B) with lockwashers. The torque for the cap-screws: 220 ft-lb dry, 170 ft-lb if the fasteners are lubricated.
- 15) Remove 3/4-10 capscrews installed in step 7, then lower bail (45) into place. Note, installing two or more 3/4-10 capscrews into bail prior to installation will simplify alignment of bail to unit.
- 16) Install and torque the twenty 3/4-10 capscrews (25C). The torque for the capscrews is 380 ft.-lbs. dry or 280 ft.-lbs. lubricated
- 17) Using a splined shaft to drive the input gear (54) ensure that the unit spins freely.
- 18) Fill the unit to the proper level, as specified, with recommended gear oil (refer to chart, page 3) after unit is sealed with brake and/or motor.

The digger is now ready to use.