



D1000 Series DiggerDrive

83,000 FT-LB TORQUE

Data Sheet PSD1000QD_3_10

Series D1000 heavy-duty planetary digger drive is ideal for construction, anchor setting, and the utility digger markets. This digger is available in a single ratio and can be purchased with or without a motor. Eskridge has over 25 years of experience in the manufacture of DiggerDrives™.

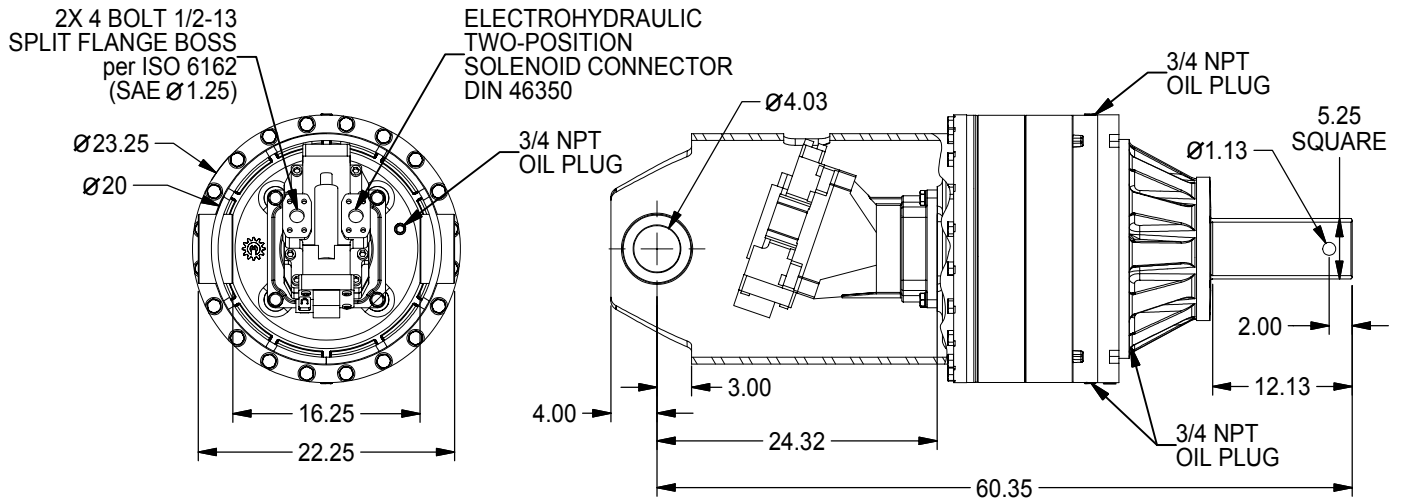

HEAVY DUTY, HIGH EFFICIENCY, COMPOUND PLANETARY DRIVE
SHAFT SIDE LOADING NOT RECOMMENDED.

TECHNICAL SPECIFICATIONS

MOTOR MOUNT OPTIONS: SAE "E" 4-BOLT
MOTOR OPTION: TWO SPEED BENT AXIS PISTON MOTOR WITH AXIAL PORTS
OPTIONAL MOTOR PART NUMBER: 01-304-0970
MOTOR RECOMMENDATIONS: 230 CC MAX, 75 CC MIN AT 5000 PSI AND 60 GPM
RATED OUTPUT TORQUES: TO 83,000 ft-lb (112,530 N-m)
MAXIMUM INPUT SPEED: 3000 rpm
OUTPUT SHAFT: 5.25 in (133.4 mm) SQUARE
SHAFT PULL-OUT: 50,000 lb (22,700 kg)
PRESSURE LOAD: 95,000 lb (43,080 kg)
OIL CAPACITY: 6.75 gal (25.6 L)
BAIL BOSS DIAMETER: 4.02 in (102.1 mm)
WEIGHT: 1,800 lb (820 kg) WITHOUT MOTOR

For more information regarding Planetary Diggerdrives and other innovative products, feel free to contact us at:



1900 Kansas City Road • Olathe, Kansas 66061 • USA

PHONE: (913) 782-1238 • FAX: (913) 782-4206

WEBSITE: www.eskridgeinc.com • E-MAIL: sales@eskridgeinc.com

Technical Data

MODEL	GEAR RATIO	MOTOR CODE	MOTOR PRESSURE	FLOW	RATED TORQUE / SPEED	
					HIGH SPEED	LOW SPEED
100096	96.0:1	97	5,000 psi (345 bar)	60 gpm (227 l/min)	26,200 ft-lb (35,520 N-m) / 32 rpm	83,300* ft-lb (112,940 N-m) / 10 rpm

*MAXIMUM INTERMITTENT VALUE.

- STARTING TORQUES ARE APPROXIMATELY 25% LESS THAN RUNNING TORQUE.
- SYSTEM BACK PRESSURE WILL REDUCE THE RUNNING TORQUES PROPORTIONALLY.
- BACK PRESSURE SHOULD BE LIMITED TO 100 psi (6,9 bar).
- HIGH ALLOY HEAT TREATED BAIL BOSS PINS REQUIRED (CUSTOMER PROVIDED).

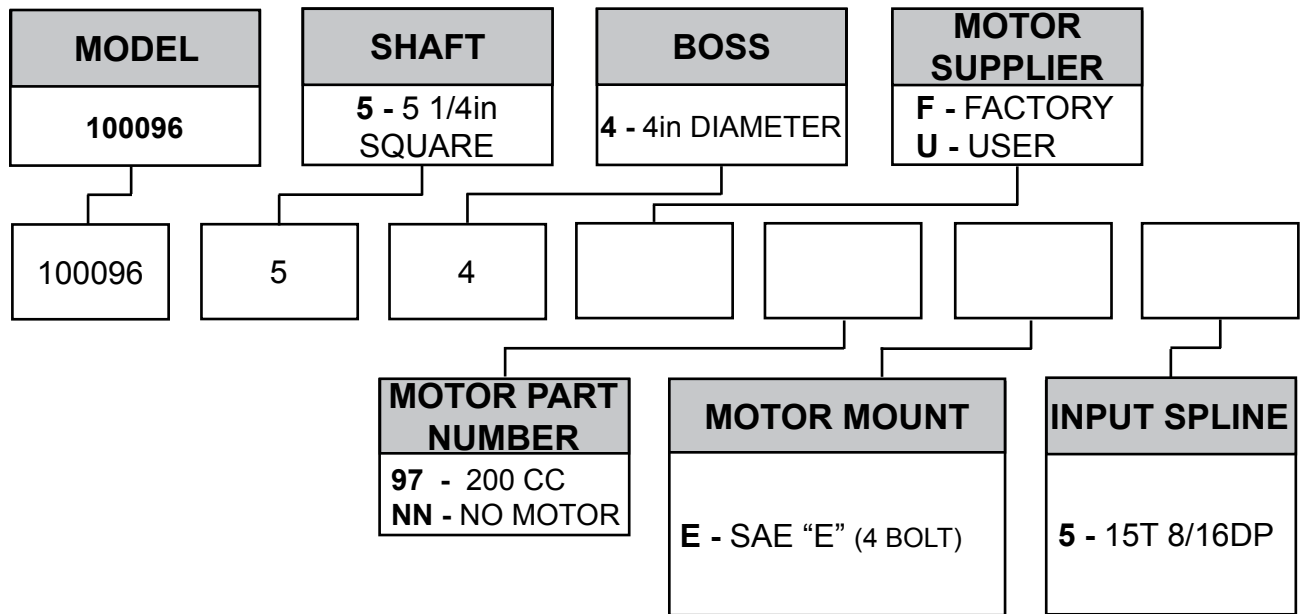

IMPORTANT INFORMATION...

ESKRIDGE, INC. EXPRESSLY DISCLAIMS ANY IMPLIED WARRANTY OF MERCHANTABILITY OR FITNESS FOR ANY PARTICULAR PURPOSE FOR THE PRODUCTS SHOWN HEREIN.

Any claims based on or related to the products shown herein will be satisfied only by repair or replacement in Eskridge, Inc.'s sole discretion to the extent covered by Eskridge's Product Warranty. Eskridge, Inc. is not liable for incidental or consequential damage of any kind or nature that relate in any way to the products shown herein. For complete warranty information, please refer to Eskridge, Inc.'s Product Warranty that applies to the products shown herein and is incorporated by this reference as if fully set forth. A copy of Eskridge, Inc.'s Product Warranty can be obtained by writing Eskridge, Inc. at P.O. Box 875, 1900 Kansas City Road, Olathe, Kansas 66061