

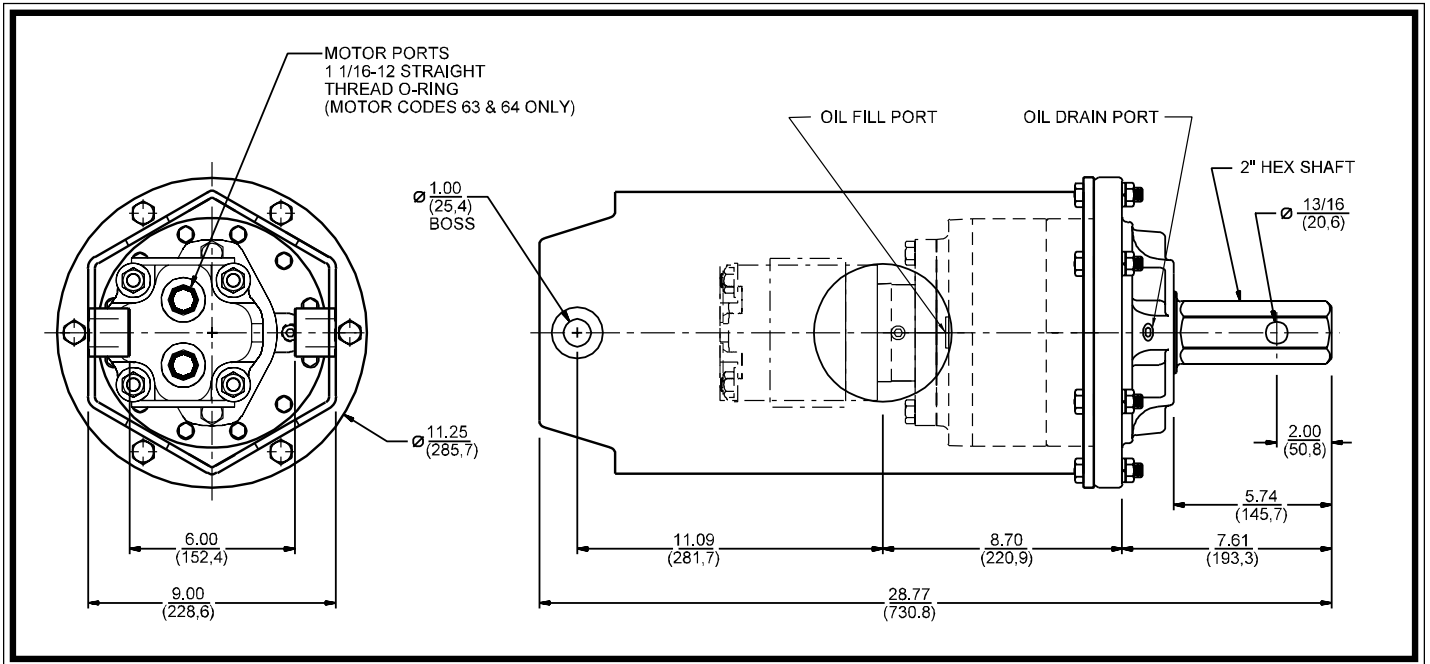

D50 Series



VALUES = inches (mm)

TECHNICAL SPECIFICATIONS

SINGLE-SPEED HEAVY-DUTY, HIGH-EFFICIENCY, PLANETARY DRIVE

RATED OUTPUT TORQUES: FROM 1500 TO 5000 ft-lb

MAXIMUM OPERATING PRESSURE: 3000 psi

MOTOR CASE DRAIN: REQUIRED WHEN BACK PRESSURE EXCEEDS 100 PSI

OUTPUT SHAFT: 2" HEX

SHAFT PULL-OUT LOAD: 5000 lb

SHAFT PRESSURE LOAD: 5000 lb

OIL CAPACITY: 2.5 pints

BAIL BOSS DIAMETER: 1"

WEIGHT: 150 lb

SHAFT SIDE LOADING NOT RECOMMENDED

NOTES:

- STARTING TORQUES ARE APPROXIMATELY 25% LESS THAN RUNNING TORQUES.
- SYSTEM BACK PRESSURE WILL REDUCE THE RUNNING TORQUES PROPORTIONALLY.
- **BACK PRESSURE SHOULD BE LIMITED TO 100 psi (6,9 bar).**
- MAXIMUM FLOW RATE IS DEPENDENT UPON MOTOR DISPLACEMENTS.
- HIGH ALLOY HEAT TREATED BAIL BOSS PINS REQUIRED (CUSTOMER PROVIDED).

1500 FT-LB

MODEL 5005-21F54

DIGGER TORQUE

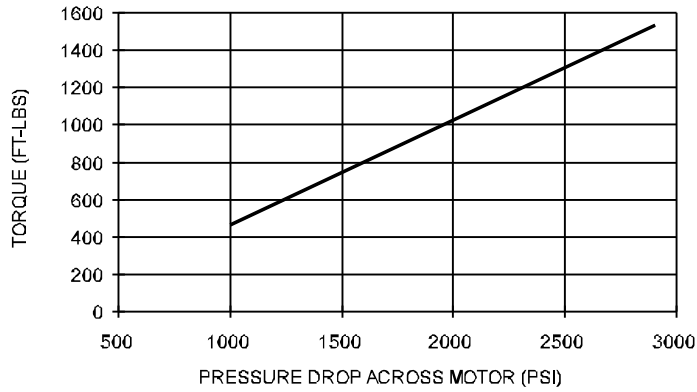

DIGGER SPEED

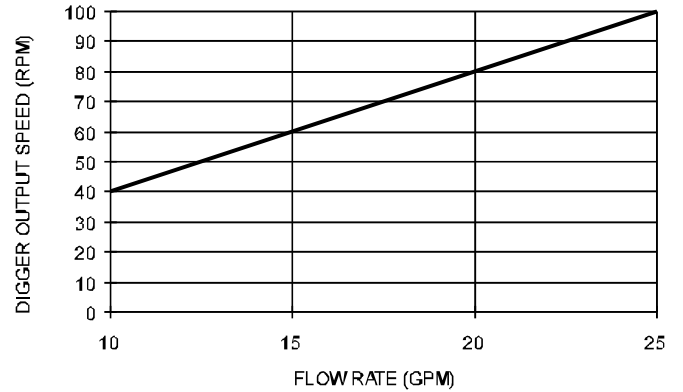

2500 FT-LB

MODEL 5005-21F55

DIGGER TORQUE

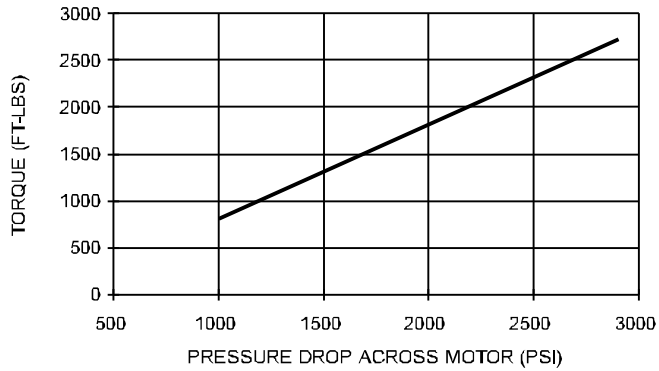

DIGGER SPEED

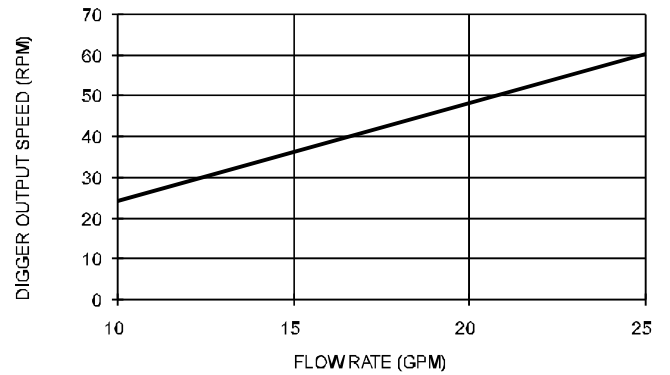

5000 FT-LB

MODEL 5016-21F54

DIGGER TORQUE

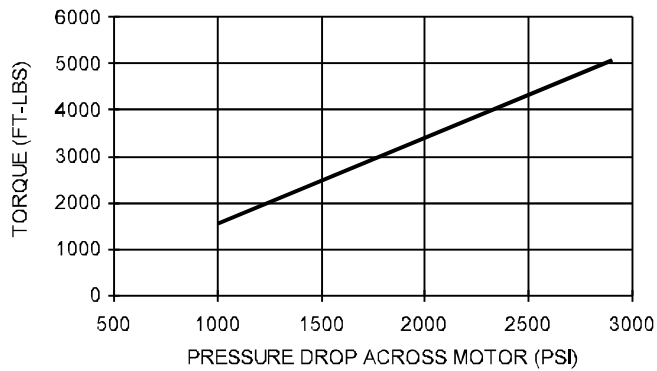

DIGGER SPEED

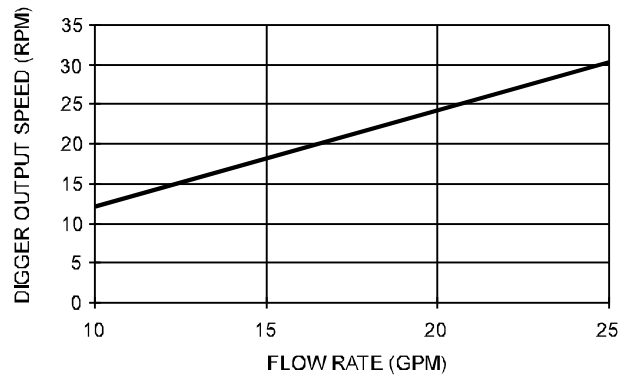

3000 FT-LB.

MODEL 5020-21F64

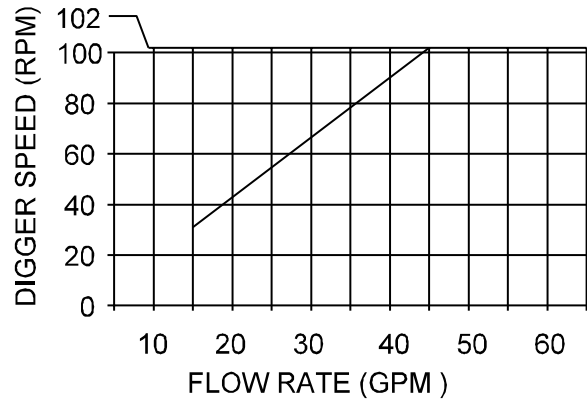
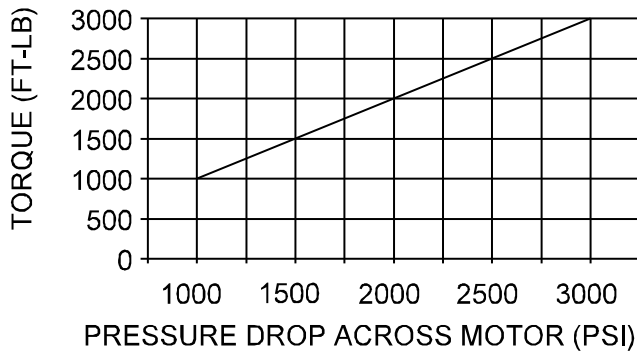

4000 FT-LB.

MODEL 5025-21F64

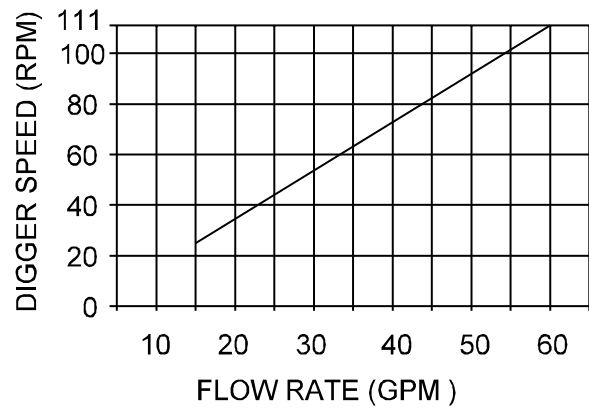
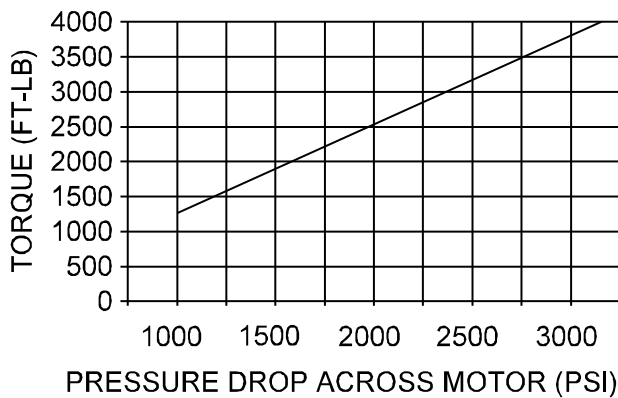

4500 FT-LB.

MODEL 5025-21F63

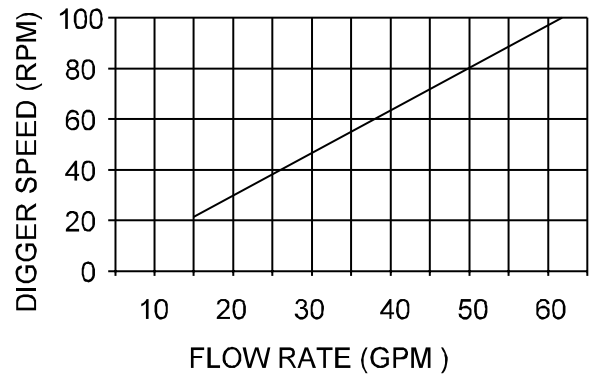
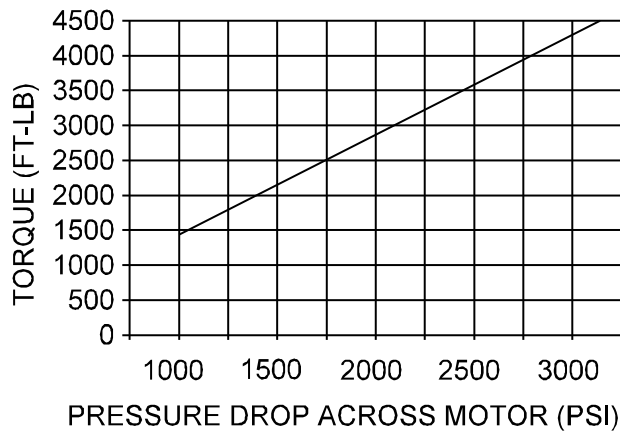

Ordering

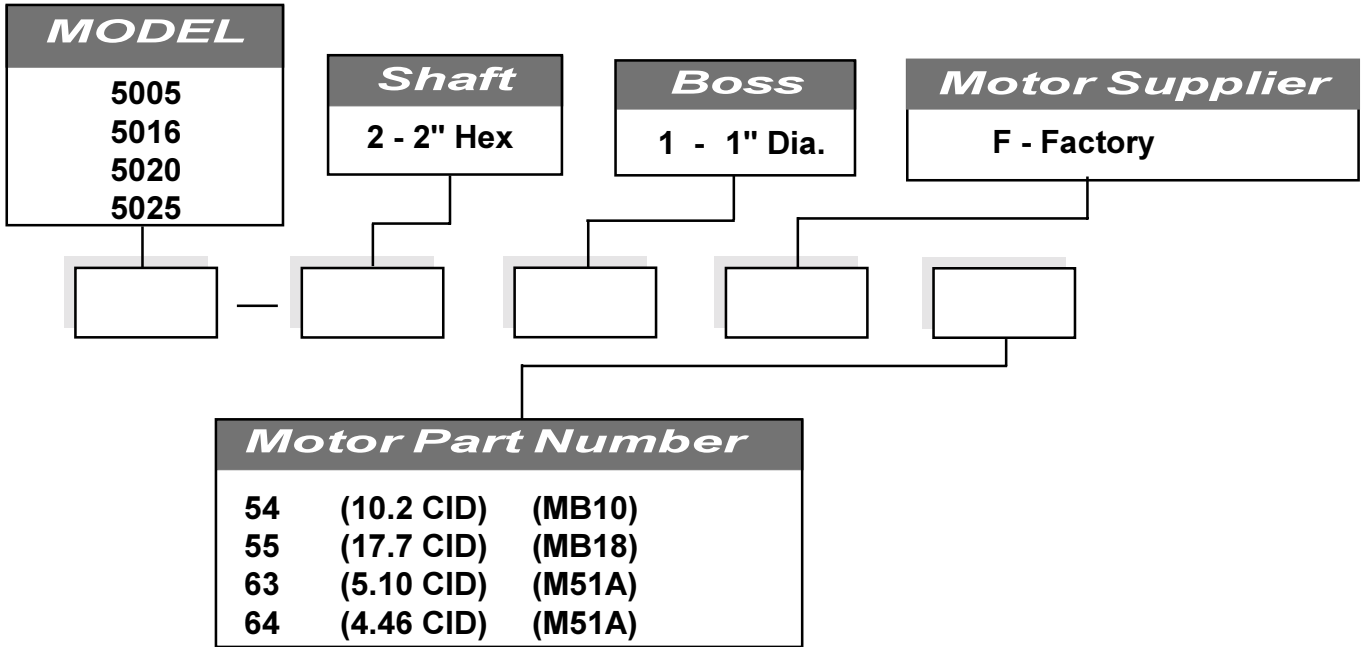

• Order number example: 5 0 0 5 - 2 1 F 5 4

IMPORTANT INFORMATION...

ESKRIDGE, INC. EXPRESSLY DISCLAIMS ANY IMPLIED WARRANTY OF MERCHANTABILITY OR FITNESS FOR ANY PARTICULAR PURPOSE FOR THE PRODUCTS SHOWN HEREIN.

Any claims based on or related to the products shown herein will be satisfied only by repair or replacement in Eskridge, Inc.'s sole discretion to the extent covered by Eskridge's Product Warranty. Eskridge, Inc. is not liable for incidental or consequential damage of any kind or nature that relate in any way to the products shown herein. For complete warranty information, please refer to Eskridge, Inc.'s Product Warranty that applies to the products shown herein and is incorporated by this reference as if fully set forth. A copy of Eskridge, Inc.'s Product Warranty can be obtained by writing Eskridge, Inc. at P.O. Box 875, 1900 Kansas City Road, Olathe, Kansas 66061



For more information regarding Planetary Geardrives and other innovative products feel free to contact us at:

1900 KANSAS CITY ROAD • OLATHE, KANSAS 66061 • USA
PHONE: (913) 782-1238 • FAX: (913) 782-4206

