

ESKRIDGE

90B MULTIPLE DISC BRAKE SERVICE AND REPAIR MANUAL

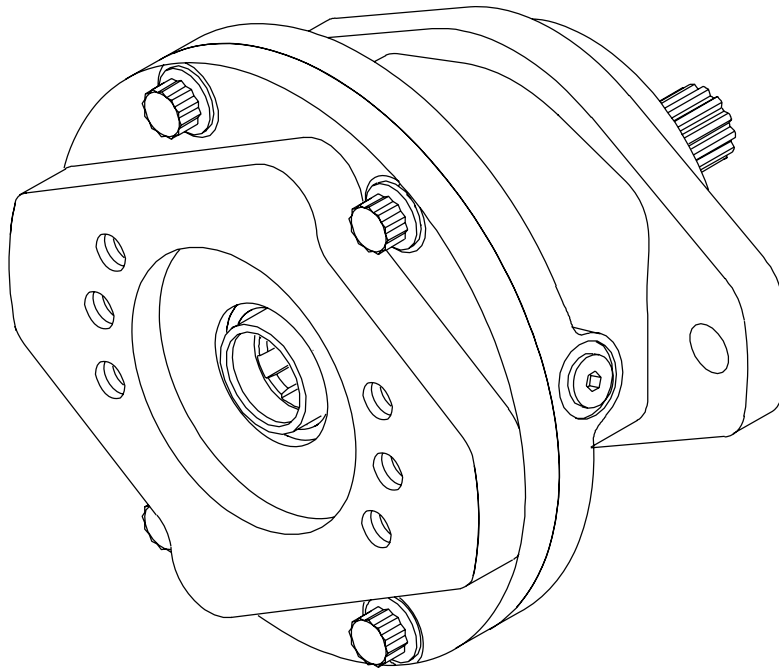

Example Part Number

90	B	2	A	3	G047	F
Series	Output Pilot	Output Spline	Input Pilot	Input Spline	Torque Code	Options

THIS SERVICE MANUAL IS EFFECTIVE
FROM: S/N 00001, OCT. 1981
TO: CURRENT
REF: SM90B-CE

90B MODEL SERVICE MANUAL

SPRING-APPLIED, HYDRAULICALLY-RELEASED, MULTIPLE-DISC BRAKE

This manual will assist in disassembly and assembly of the above model brakes. Item numbers, indicated in parentheses throughout this manual, refer to the exploded parts breakdown drawing. Individual customer specifications may vary from exploded drawing and standard part numbers shown; if applicable, refer to individual customer drawing for details.

The Model 90B Series Eskridge brake is a spring applied, hydraulically released, multiple disc parking brake. The 90B is designed for "fail-safe" type operations. Temperature, wear, and contamination of the friction surfaces will affect the performance of the brake and should be taken into consideration when specifying a required torque rating. Care should be taken to avoid damaging the splines or mounting surfaces during installation. The model 90B is not intended for use in dynamic applications. Please contact the Eskridge Sales Department about any flow through applications. Brake operation should be tested during normal service operation. Brake inspection and service should be part of the normal service and maintenance schedule of the equipment or vehicle on which it is used. Any loss of holding torque requires the removal, inspection and replacement of suspect components.

SPECIFICATIONS

Maximum pressure.....	3,000 PSI (Unless 'E'-high pressure option is specified)
Maximum continuous pressure.....	3,000 PSI (Unless 'E'-high pressure option is specified)
Maximum speed.....	3,900 RPM
Shaft splines.....	30° involute, flat root side fit per ANSI B92.1a-1976 internal-class 7, external-class 5
Maximum output spline torque.....	4000 lb-in for code 2, 13T 16/32 8000 lb-in for code 3, 1-6B
Maximum operating temperature.....	170°F
Volume of oil to release brake.....	.3 cu. in.
Approximate weight.....	25 lbs.

Torque ratings are based on standard friction material in ATF-F fluid media or dry bronze at (0) PSI back pressure. Break away torque may vary +/-10% from specified ratings. The "W" wet option applies to bronze friction discs only and is furnished with mineral base hydraulic oil. Torque rating for wet bronze brakes will vary depending upon the type of oil used. Use only mineral base hydraulic oil for release of brake. For flow-thru option "F", use only fluids that are compatible with internal seals. Use of fluids other than specified above will alter torque values.

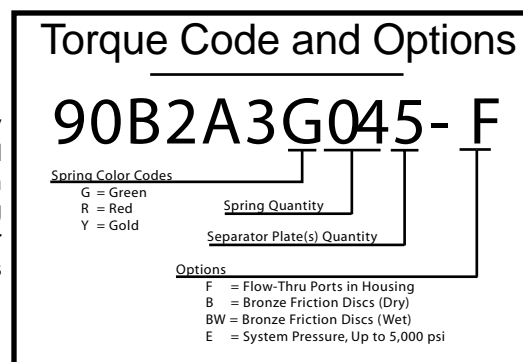

WARNING: While working on this equipment, use safe lifting procedures, wear adequate clothing and wear hearing, eye and respiratory protection.

CONTENTS

Example Part Number	1
Specifications	2
Installation.....	3
Disassembly.....	3
Inspection.....	3
Assembly.....	4
Exploded View Drawing	5
Eskridge Product Warranty	6
Eskridge Products.....	7

Installation

NOTE: Before beginning installation procedures, visually inspect brake mounting flanges and shaft splines for damage due to poor handling during shipping. Do not use brake if damage is excessive.

- 1) The 90B brake is supplied with the necessary o-rings and/or gaskets for mounting the brake to a gearbox and a motor to the brake.
- 2) Mount 90B brake with (2) 1/2-13x1 capscrews through brake mounting flange. On horizontal shaft mountings, one o-ring port should be oriented as close to top as practical (bleeder port). Some installations require that brake be "released" so it can be rotated to align bolt holes (See Step 6 of installation instructions).
- 3) Attach motor to input end of brake with appropriate sized capscrews through motor flange and gasket to give approximately 1/2" thread engagement. Make sure capscrews do not bottom out when fully tightened.
- 4) Torque all capscrews to approximately 75% of their yield strength. Refer to the chart below for appropriate thread size and torque loads:

**Threaded Fastener Installation Torque
(ft-lbs)**

Thread Size	SAE Grade 5		SAE Grade 8	
	Dry	Lubed	Dry	Lubed
3/8-16	30	23	45	32
1/2-13	75	55	110	80
5/8-11	150	110	220	170
3/4-10	260	200	380	280

- 5) Remove protective plug from pressure port of brake and attach a pressure line with 7/16-20 UNF-2B straight thread ring fitting.
- 6) Apply low pressure (20-30 PSI) to brake release port. Loosen Hollow Hex Plug, opposite of pressure port just enough to allow hydraulic fluid to bleed from cavity. After air has been bled from brake, tighten plug.

Disassembly

- 1) Remove motor from brake.
- 2) Loosen four 1/2-13x1 12-Point Capscrews (8). Alternately unscrew capscrews 1 turn at a time until all internal spring force is relieved. Remove cover (2) and springs (10).

CAUTION: Do not clamp or otherwise restrain cover (2) while removing cover bolts (8) since the brake is under high compressive spring load.

- 3) Apply low pressure air (20-30 PSI) to brake release port while holding one hand on top of piston (3). The air will force piston out of case. If friction discs (11) will be reused, turn brake upside down so that hydraulic oil cannot run down into case (1) as piston is forced out.
- 4) Remove shaft (4).
- 5) Friction discs (11), separator plates (12) and spacers (5) may now be removed from case (1). If your brake has a full complement of friction discs (11) and separator plates (12), it will not have any spacers (5).
- 6) Remove seal (18) and bearing (6).

Inspection

- 1) Friction discs (11) should be replaced when overall height of stack of spacers (5), friction discs (11) and separator plates (12) is less than 1.230". This overall height represents an approximate 10% decrease in holding torque from that of a new brake.
- 2) Inspect piston o-rings (13, 14, 15 & 16) for signs of abrasion, extrusion or other damage.

NOTE: Standard o-rings for 3,000 PSI are black nitrile. Option 'E' Extra Pressure o-rings for 5,000 PSI system pressure are light yellow or cream colored urethane.

Assembly

Assembly should be in reverse order of disassembly with the following additional instructions.

- 1) Install shaft (4) by pushing shaft downward through bearing (7) and Seal (18) until bearing shoulder on shaft is seated against bearing.
- 2) Friction pack [Spacer (5), Friction Disc (11) and Separator Plate (12)] must be installed in exactly the same order as they were removed. There must always be a Friction Disc (11) above and below each Separator Plate (12). If a Separator Plate (12) is placed next to the Piston (3) or Spacer (5), the unit will overheat and seize up. Be careful not to contaminate the friction surfaces with dirt, grease or fluid media* other than what is specified by your particular brake.

NOTE: If installing new friction discs (11), soak all discs in specified fluid media* before installation.

- 3) Pour appropriate fluid media, approximately 1 1/2 oz., over the friction plates or until the fluid level is even with top friction disc (11). See Fluid Media Table below.

Fluid Media Table

Option Code	Friction Disc Lining	Fluid Media
None (Standard)	Paper Composite	Automatic Transmission Fluid, ATF-Type F
B	Bronze (Dry)	None
BW	Bronze (Wet)	Mineral Base Hydraulic Oil

*Other fluids such as Dextron III will deliver lower holding torque. Contamination of ATF-F with hydraulic or other oils will also lower holding torque.

It is recommended that spring holes in piston be filled with fluid (1/2 oz.) after piston is installed. This will prevent fluid that is below piston from being trapped above it when brake is turned to horizontal position and back to vertical.

- 4) If replacing piston o-rings, be sure o-rings (15 & 16) are nearest each other with backup rings (13 & 14) to the outside after installing onto Piston (3). Flat side of back-up-ring must be placed next to piston groove wall, curved face toward o-ring. Lubricate o-rings and bores with silicone based lube or with mineral base oil. Gently slide Piston (3) into case (1) until large o-ring (16) touches case. Press down firmly on piston using heel of both hands. This will squeeze o-rings into case and set piston (3) against friction plates. Do not use a hammer or mallet to install piston.
- 5) Insert springs (10) into piston (3) evenly or symmetrically spaced.
- 6) Install cover o-ring (17) around lip on case (1).
- 7) Install item (7), ball bearing or thrustwasher, on shaft.

- 8) Set cover (2) on top of springs (10) over input end of shaft (4). Start four capscrews (8) through cover and into case with your fingers. Alternately tighten cover bolts one turn at a time until cover is tight against case. Torque bolts to 80 ft-lbs.

NOTE: Maximum operating pressure is 3,000 PSI with standard nitrile o-rings on piston and 5,000 PSI with 'E' option urethane o-rings. Operation above this pressure is detrimental to the life of the brake and could be dangerous.

THE BRAKE IS NOW READY FOR USE.

Repair Kits

Due to the many torques and release pressure combinations available, it is impossible to detail each style and supply a repair kit for individual models. The repair kits listed below will work with all combinations of torque vs. release pressure, input mountings and friction plates. It is entirely possible to have "extra" parts left over from the repair kits after you have complete the repair or maintenance. If you are not sure about what is required for your brake and its configuration, please contact Eskridge's sales department.

Friction Disc Kit, Paper 90-016-2131

01-288-0010 Friction Disc, Paper (8)

Friction Disc Kit, Bronze 90-016-3051

90-004-1742 Friction Disc, Bronze (8)

Separator Plate Kit 90-016-2141

01-288-0020 Separator Plate (7)

Seal Kit - Standard 90-016-2011

01-400-0120 Back-up Ring, Piston (1)

01-400-0140 Back-up Ring, Piston (1)

01-402-0450 O-Ring, Piston (1)

01-402-0470 O-Ring, Piston (1)

01-402-0580 O-Ring, Case Seal (1)

01-405-0340 Shaft Seal (1)

90-004-1061 Gasket, Mtr. SAE "A" (4 bolt) (1)

90-004-1091 Gasket, Mtr. SAE "B" (2 bolt) (1)

90-004-1111 Gasket, Base (1)

Master Rebuild Kit, Paper - Standard 90-015-3021

90-016-2131 Friction Disc Kit, Paper (1)

90-016-2011 Seal Kit (1)

01-100-0110 Bearing, Output (1)

01-100-0120 Bearing, Input (1)

Master Rebuild Kit, Bronze - Standard 90-015-3071

90-016-3051 Friction Disc Kit, Bronze (1)

90-016-2011 Seal Kit (1)

01-100-0110 Bearing, Output (1)

01-100-0120 Bearing, Input (1)

Option 'E'-Extra Pressure Option (5.000 PSI) Kits

Seal Kit - High Pressure 90-016-2051

Same as standard seal kit,
but the following parts are substituted:

01-402-0850 for 01-402-0450, O-Ring, Piston

01-402-0860 for 01-402-0470, O-Ring, Piston

Master Rebuild Kit, Paper - High Pressure 90-015-3081

Same as standard master rebuild kit, paper,
but the following parts are substituted:

90-016-2051 for 90-016-2011, Seal Kit

Master Rebuild Kit, Bronze - High Pressure 90-015-3091

Same as standard master rebuild kit, bronze,
but the following parts are substituted:

90-016-2051 for 90-016-2011, Seal Kit

Exploded View Drawing

OPTIONAL KITS	PART NO.		ITEMS INCLUDED
	(STANDARD)	(E OPTION)	
SEAL KIT	90-016-2011	90-016-2061	(1) EACH 3/32 14, 15, 16, 17, 18, 90-004-1061, 90-004-1081, 90-004-1101 & 90-004-1111
FRICITION DISC KIT	90-016-2131	90-016-2131	P/N 01-288-0010 (8 EACH)
MASTER REBUILD KIT (PAPER)	90-016-3021	90-015-3081	6, 7, SEAL & PAPER FRICTION KITS
SEPARATOR PLATE KIT	90-016-2141	90-016-2141	ITEM 12 (7 EA.)
FRICITION DISC KIT (BRONZE)	90-016-3051	90-016-3051	P/N 90-004-1742 (8 EA.)
MASTER REBUILD KIT (BRONZE)	90-016-3071	90-015-3081	6, 7, SEAL & BRONZE FRICTION KITS

COVER	PART NO.
SAE A (2 & MOD 4 BOLT)	90-004-1413
SAE A (4-BOLT DANFOSS MTR)	90-004-1803
SAE B (2&4 BOLT)	90-004-1143
SAE C (2&4 BOLT)	90-004-2263 **

SHAFT IN/OUT	PART NO.
6B/13T	90-004-1043
13T/13T	90-004-1163
14T/13T	90-004-1403
6B/8B	90-004-1303
13T/6B	90-004-1573
14T/6B	90-004-1383

QTY. OF SPRINGS MUST BE 2, 4, 5, 6, 8 OR 10 SYMMETRICALLY SPACED.
 TOTAL QTY OF SEPARATORS (ITEM 12) AND SPACERS (ITEM 5) MUST EQUAL 7.
 QTY OF FRICTION DISCS (ITEM 11) = QTY OF SEPARATORS (ITEM 12) PLUS 1.
 A FULL COMPLETE BRAKE INCLUDES 8 FRICTION DISCS (ITEM 11), 7 SEPARATORS (ITEM 12), AND 0 SPACERS (ITEM 5). THE QTY OF ALL ITEMS ABOVE IS DETERMINED BY TORQUE AND RELEASE PRESSURE REQUIREMENTS.

BRAKE WITH 14T INPUT SPLINE REQUIRES THE FOLLOWING:

ITEM	DESCRIPTION	SAE A/B	SAE C	SAE C
3	THRUST WASHER	90-004-1632	01-112-0280	**
27	RETAINING RINGS	01-112-0280	01-160-0620	**

** SAE C COVER 90-004-2263 IS NOT AVAILABLE WITH OTHER THAN 14T INPUT SPLINE.

3. CASE (ITEM 1) WITH FLOW-THRU PORTS REQUIRES (4) 1/8 NPT PLUGS P/N 01-207-0300 (NOT SHOWN).

4. STANDARD PISTON O-RINGS FOR 3,000 PSI ARE BLACK NITRILE. OPTION E EXTRA PRESSURE O-RINGS FOR 5,000 PSI SYSTEM PRESSURE ARE LIGHT YELLOW OR CREAM COLORED URETHANE.

ECN 2196 X90B-CE DATE: 04-20-04

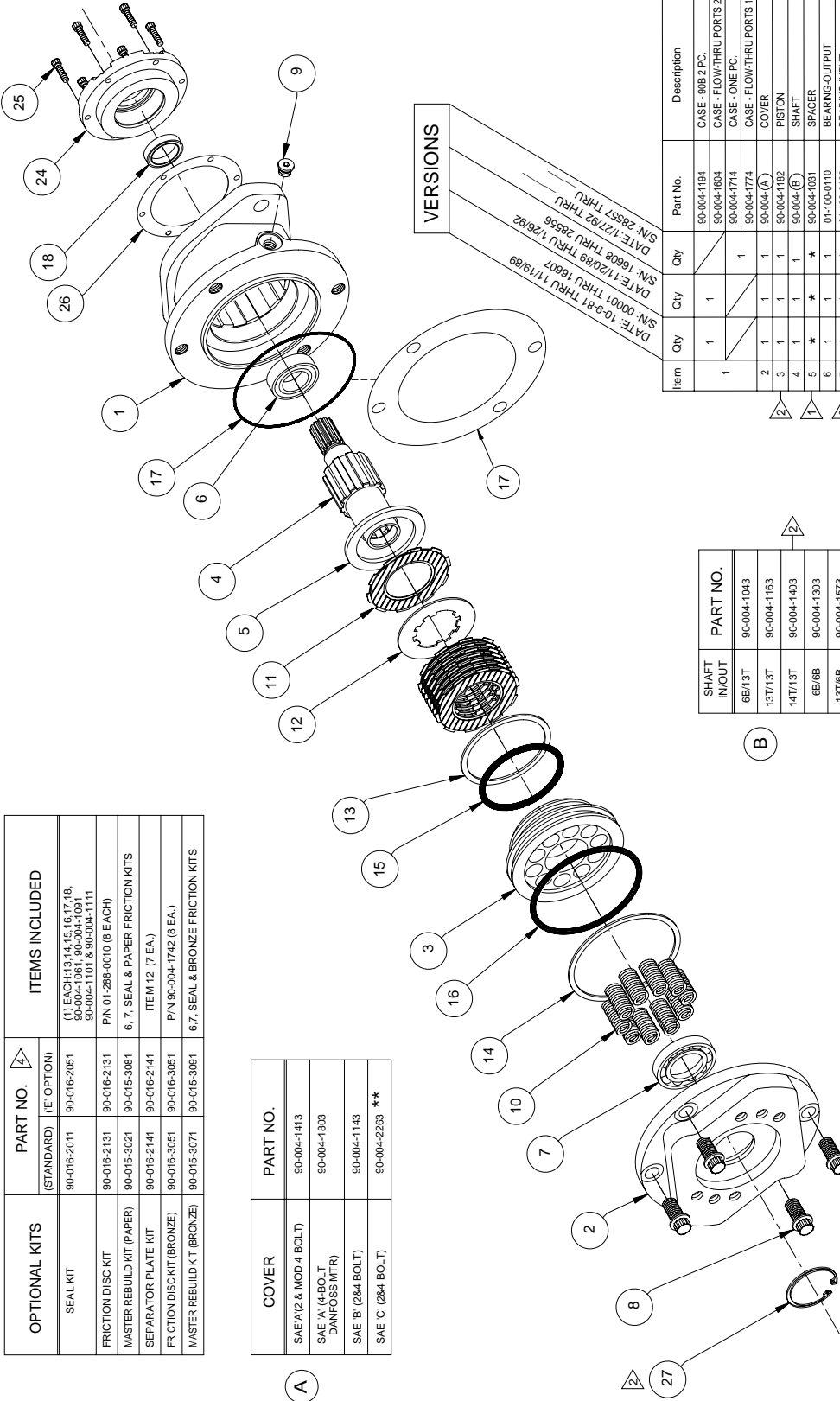

Item	Qty	Part No.	Description
1	1	90-004-1184	CASE - 90B 2 PC
		90-004-1604	CASE - FLOW-THRU PORTS 2 PC.
		90-004-1774	CASE - ONE PC.
2	1	90-004-1774	CASE - FLOW-THRU PORTS 1 PC.
3	1	90-004-A	COVER
4	1	90-004-B	PISTON
5	*	90-004-1031	SPACER
6	1	01-100-0110	BEARING-OUTPUT
7	1	01-150-1040	BEARING-INPUT
8	4	01-100-0120	12 PT. CAPSCREW (1/2-13X)
9	1	01-208-0020	HOL. HEX. PLUG (7/16-20)
10	*	01-261-0290	SPRING - (GREEN)
		01-261-0300	SPRING - (GOLD)
		01-261-0310	SPRING - (RED)
11	*	01-288-0010	FRICTION DISC (PAPER)
12	*	90-004-1742	FRICTION DISC (BRONZE)
13	*	01-288-0020	SEPARATOR PLATE
14	1	01-400-0120	BACK-UP RING
15	1	01-400-0140	BACK-UP RING
		01-402-0450	O-RING (STANDARD)
		01-402-0650	O-RING (E OPTION)
16	1	01-402-0470	O-RING (STANDARD)
		01-402-0680	O-RING (E OPTION)
17	1	01-402-0680	O-RING
		90-004-1101	GASKET
18	1	01-408-0340	SEAL
24	1	90-004-1052	BASE
25	6	01-150-1030	SOC.HD.CAPSCREW (1/2-24X3/4)
26	1	90-004-1111	GASKET - BASE

2 PC. BRAKE ONLY

ESKRIDGE Model 90B

Eskridge Product Warranty

ESKRIDGE, INC. ("Eskridge") warrants to its original purchaser ("Customer") that new component parts/units ("Units") sold by Eskridge will be free of defects in material and workmanship and will conform to standard specifications set forth in Eskridge sales literature current at the time of sale or to any custom specifications acknowledged by written Customer approval of drawings, SUBJECT TO THE FOLLOWING QUALIFICATIONS AND LIMITATIONS:

1. Prior to placing Units in service, the Customer shall provide proper storage such that foreign objects (e.g., rain or debris) cannot enter any Units via entry ports which are normally closed during operation.
2. The Customer must notify Eskridge in writing of any claim for breach of this warranty promptly after discovery of a defect. The warranty period shall commence when a unit is placed in service and shall expire upon the earlier of
 - a. the expiration of twelve (12) months from the date of Commencement of Service (as defined in Paragraph 4)
 - b. the completion of one thousand (1000) hours of service of the Units
 - c. the expiration of six (6) months after the expiration of any express warranty relating to the first item of machinery or equipment in which the Units are installed or on which it is mounted, or
 - d. the installation or mounting of the Units in or on an item of machinery or equipment other than the first such item in which the Units are installed or on which the Units are mounted.
3. Units shall be deemed to have been placed in service (the "Commencement of Service") at the time the machinery or equipment manufactured or assembled by the Customer and in which the Units are installed or on which the Units are mounted is delivered to the Customer's dealer or the original end-user, whichever ever receives such machinery or equipment first.
4. This warranty shall not apply with respect to Units which, upon inspection by Eskridge, show signs of disassembly, rework, modifications, lack of lubrication or improper installation, mounting, use or maintenance.
5. Eskridge makes no warranty in respect to hydraulic motors mounted on any Units. Failure of any such motor will be referred to the motor manufacturer.
6. Claims under this warranty will be satisfied only by repair of any defect(s) or, if repair is determined by Eskridge in its sole, absolute and uncontrolled discretion to be impossible or impractical, by replacement of the Units or any defective component thereof. No cash payment or credit will be made for defective materials, workmanship, labor or travel. IN NO EVENT SHALL ESKRIDGE BE LIABLE FOR INCIDENTAL OR CONSEQUENTIAL DAMAGES OF ANY KIND OR NATURE, FOR WHICH DAMAGES ARE HEREBY EXPRESSLY DISCLAIMED.
7. From time to time, Eskridge may make design changes in the component Units manufactured by it without incorporating such changes in the component Units previously shipped. Such design changes shall not constitute an admission by Eskridge of any defects or problems in the design of previously manufactured component Units.
8. All freight charges on Units returned for warranty service are the responsibility of the Customer.

Warranty Return Policy

1. Any part/Unit(s) returned to Eskridge must be authorized by Eskridge with an assigned return (CSR) number.
2. All Units shall be returned freight prepaid.
3. Any Units qualifying for warranty will be repaired with new parts free of charge (except for freight charges to Eskridge as provided above).
4. If Units are found to be operable, you have two options:
 - a. The Units can be returned to you with a service charge for inspection, cleaning, and routine replacement of all rubber components and any other Units that show wear;
 - b. We can dispose of the Unit(s) at the factory if you do not wish it to be returned.

NOTE: Any order of Units by customer shall only be accepted by Eskridge subject to the terms stated herein. Any purchase order forms used by Customer (to accept this offer to sell) which contain terms contrary to, different from, or in addition to the terms herein shall be without effect, and such terms shall constitute material alteration of the offer contained herein under K.S.A 84-2-207 (2)(b), and shall not become part of the contract regarding the sale of the Units.

The foregoing warranty is the sole warranty made by Eskridge with respect to any Units and is in lieu of any and all other warranties, expressed or implied. There are no warranties which extend beyond the description on the face hereof without limiting the generality of the foregoing, Eskridge expressly disclaims any implied warranty of merchantability or fitness for any particular purpose, regardless of any knowledge Eskridge may have of any particular use or application intended by the purchaser. The suitability or fitness of the Units for the customer's intended use, application or purpose and the proper method of installation or mounting must be determined by the customer.

ESKRIDGE PRODUCTS

Planetary Gear Drives

SERIES	MODELS	TORQUE RATING (IN-LB) MAX. INTERMITTENT
20	20B, 20P, 20LB, 20LP	20,000
28	28B, 28P, 28M, 28LB, 28LP	50,000
50	50K/L, 50LG, 50N	50,000
65	60B, 60E, 60L	60,000
100	100E	100,000
105	105E	100,000
130	130	130,000
150	150	150,000
250	250K/L, 251K/L, 252K/L, 253K/L	250,000
600	600K/L	600,000
1000	100K/L	1,000,000

Multiple Disc Brakes

SERIES	FEATURES	TORQUE RATING (IN-LB)
90B	SAE B	TO 4,800
90BA	SAE B, ADJUSTABLE TORQUE	TO 4,800
92B	SAE B, LOW PROFILE	TO 2,800
93	FOR NICHOLS MOTORS	TO 6,100
95C	SAE C	TO 12,000
98D	SAE D	TO 25,000

Planetary Auger Drives, Anchor Drives & Diggers

SERIES	MODELS	TORQUE RATING (FT-LB)
D50	1500, 2500 & 5000	1,500 - 5,000
76	BA & BC, 2-SPEED	8,000 - 12,500
77	BA, BC & BD	6,000 - 12,500
78	35 & 48, 2-SPEED	9,000 - 12,500
75	38 & 51, 2-SPEED	16,500 - 20,000
D600	D600	50,000
D1000	D1000	83,000

