

EXAMPLE PART NUMBER: 98 D 9 C 4 B0608 D

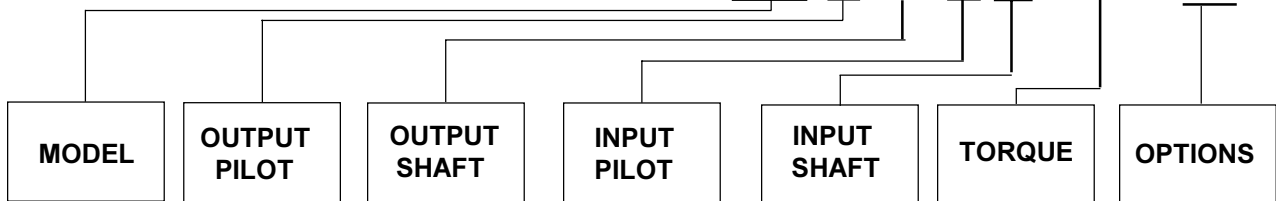

98D Series Brake Service & Repair Manual

EFFECTIVE FOR:
S/N: 36992 - UP
DATE: 09/13/94 - UP

MODEL 98D SERVICE MANUAL

This manual will assist in disassembly and assembly of major components for all Model 98D Brakes. Item numbers, indicated in parentheses throughout this manual, refer to the Eskridge Model 98D exploded parts breakdown drawings. Individual customer specifications (mounting case, output shaft, brake assembly, etc.) may vary from exploded drawing and standard part numbers shown. If applicable, refer to individual customer drawing for details.

The Model 98D series Eskridge brake is manufactured for two specific types of holding torque requirements. The standard "fail-safe" requirement and the "slip protection" requirement. Both types are spring loaded (normally applied) with a hydraulic pressure required for release. All brakes are individually tested at the factory for function, leaks and static breadaway torque. Fail-safe type brakes are tested to be assured they are in excess of 110% of the fail-safe torque rating for the unit. A failsafe brake should be used when the only requirement is a minimum static holding torque. A slip protection brake should be used where an accurate specified torque is required, such as a side load protection on a crane or overload protection in a drivetrain. These brakes are tested to be within +/- 10% of the slip protection rating for the unit.

SPECIFICATIONS

Maximum pressure	3,000 PSI	Maximum operating temperature	170°F
Maximum continuous pressure	3,000 PSI	Volume of oil to release brake	.50 cu. in.
Maximum speed	3,900 RPM	Approximate weight	59 lbs.
Shaft splines	30° involute, flat root side fit per ANSI B92.1-1970 Internal-class 7 External-class 5	Breakaway torque may vary +/- 10% from specified ratings. Use only mineral base hydraulic oil to release brake.	

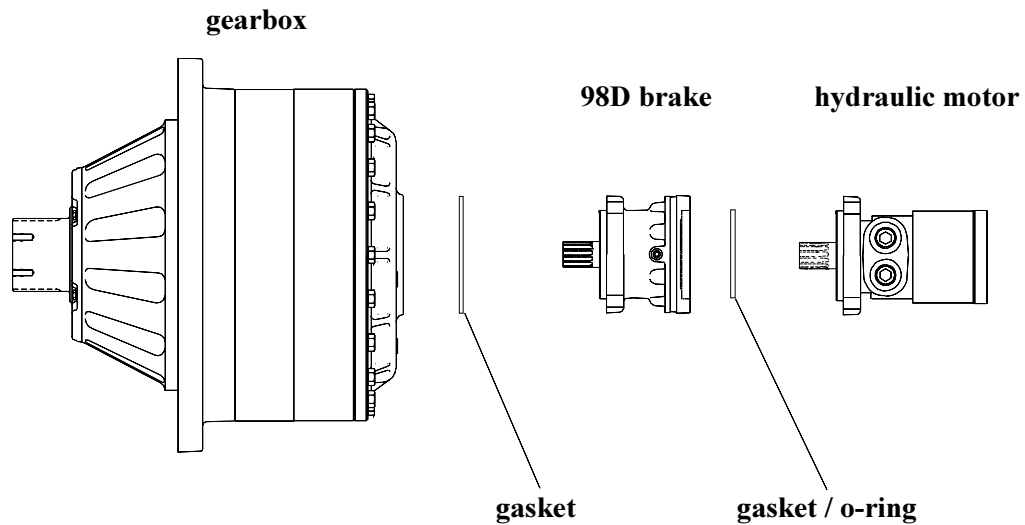



WARNING: While working on this equipment, wear adequate protective clothing, hearing, eye and respiratory protection. Use safe lifting procedures.

Installation

NOTE: Before beginning installation procedures, visually inspect brake mounting flanges and shaft splines for damage during shipping.

- 1) Position brake and motor for mounting and to orient the bleed and release ports as required. If mounted with shaft horizontal, the bleed port should be at top. It might be necessary to release brake before it can be rotated to align mounting holes. If so, follow instructions in steps 5 and 6 prior to applying release pressure!
- 2) Use only SAE grade 5 (or better) fasteners for mounting brake and motor.
- 3) Allow at least one thread diameter of thread engagement when selecting fastener lengths. Be sure fasteners will not bottom out when fully tightened.
- 4) See torque chart below for torque values.
- 5) Remove plastic protective plug from pressure port of brake and attach a hydraulic pressure line with a 7/16-20UNF-2A straight thread o-ring fitting. Use only mineral based hydraulic oil to test and operate the brake.
- 6) Apply low pressure (20-30 PSI) to brake release port. Loosen hollow hex plug (10) opposite pressure port just enough to allow air to bleed from between piston o-rings. After air has been bled from brake, remove pressure, tighten plug.

TORQUE IN FT-LBS

THREAD SIZE	SAE GRADE 5		SAE GRADE 8	
	DRY	LUBED	DRY	LUBED
3/8-16	30	23	45	35
1/2-13	75	55	110	80
5/8-11	150	110	220	170
3/4-10	260	200	380	280

Disassembly

- 1) Remove any plugs and fittings from the brake pressure and bleed ports. Drain, or blow out, as much hydraulic oil as possible from the brake into a suitable container for proper disposal.
- 2) Place brake on stable work platform, shaft down. Support the brake so it won't fall over.
- 3) Remove the eight socket head capscrews (7) from input end of brake. The capscrews and cover (2) are under spring load. The capscrews should be loosened gradually and uniformly.
- 4) Remove cover. This will expose the internal components of the brake. The case seal o-ring (18) will be attached to the cover pilot. Inspect the o-ring and replace with a new one if worn or damaged.
- 5) Note the color, number, and spacing of the springs (11) then remove them from piston (3). Inspect springs and replace with new ones if damaged, broken or discolored from heat.
- 6) Support the brake, with shaft up, in such a way that the piston can be pushed out the bottom. Two pairs of stacked 2 x 6 wood blocks work well.
- 7) Remove retaining ring (8) from the shaft (4).
- 8) Using a soft-faced hammer, drive the shaft and piston down out of the case.
- 9) Remove the case. Note arrangement of friction discs (12), separator plates (13), and spacers (5).
- 10) Remove friction discs, separator plates and spacers. Friction discs should be replaced with new ones if oil soaked (dry brakes only). Any friction discs or separator plates that are damaged, warped, or excessively worn should be replaced with new ones.
- 11) Friction discs should be replaced if less than .080 inch thick. Separator plates should be replaced if less than .081 inch thick.
- 12) Inspect brake shaft splines and bearing journals for abnormal wear or damage.

13) Remove o-rings and back-up rings (**14, 15,16,17,18**) from piston. Replace with new ones if worn or damaged.

14) If damaged, the oil seal (**19**) and bearing (**6**) can be removed and replaced. Check for wear spots or nicks on the sealing lip of oil seal. Rotate inner race of bearing: rotation should be smooth and without excess drag.

Remove retaining ring (**9**) before attempting bearing removal.

Assembly

NOTE: *Parts must be clean and dry before assembly. Visually inspect components for damage and abnormal wear. Do not use damaged or worn parts.*

1) Place brake case (**1**) on a stable work platform, bearing side down. If the oil seal (**19**) and bearing (**6**) are not being replaced skip to step number 5.

2) Install seal from inside case, pressing until top of seal is flush with case. Open side of seal should be toward inside of brake. A seal installation tool is recommended.

3) Press in bearing (**6**) from outside. Press against the bearing outer race until the bearing is fully seated in the case. A bearing installation tool is recommended.

4) Install retaining ring (**9**) into the case.

5) Support the case in such a way that allows room for the shaft (**4**) to protrude out the bottom. Two pairs of stacked 2 x 6 wood blocks work well.

6) Push the shaft downward through oil seal and bearing until shaft shoulder is seated against bearing.

7) Install retaining ring (**8**) on shaft.

8) If the brake uses spacers (**5**), install them.

9) Install separator plates (**13**) and friction discs (**12**) in exactly the same order as they were removed. There should be a friction disc on the top and bottom of the stack. Do not place a separator plate next to the piston. *Be careful not to contaminate the friction disc or separator plate surfaces with dirt, grease, or fluid other than the brake was designed to use.*

10) If replacing piston o-rings (**16&17**) and piston back-up

rings (**14&15**), be sure o-rings are nearest each other with back-up rings to the outside of the piston (**3**). Lightly lubricate piston bores and o-rings. *Take care not to get lubricant onto friction pack.*

11) Gently slide piston into case until larger o-ring touches case. Using a light to medium duty press, push piston completely into bore. This will squeeze the o-rings and back-up rings and set piston against friction pack.

12) Place springs (**11**) into spring pockets in piston. Arrange springs in a symmetrical pattern.

13) For optional double bearing brakes, install bearing into cover (**2**).

14) Install case seal o-ring (**18**) onto pilot of cover.

15) Set cover on top of piston, springs, and input end of shaft.

16) Apply a non-hardening thread-locking compound to each cover capscrew (**7**) and start each one into the case by hand. Tighten cover capscrews 1/2 turn at a time in a crisscross pattern until cover is tight against the case. Tighten to the torque shown in the chart on page 3. *A light to medium duty press can be used to push the cover down on to the case so the cover bolts can be installed more easily.*

17) The brake is now ready for minor testing of fit, function and release pressure. Use only mineral based hydraulic oil to test and operate Eskridge multiple disc brakes. **Bleed brake before pressurizing.** To test release pressure, place the hollow hex (**ITEM 10**) plug in one of the brake ports. Connect a hydraulic power source (either a hand pump or port-a-power) to the other brake port. Bleed air from brake, then pressurize the brake slowly to the advertised release pressure, both initial and full. As you pressurize the brake, rotate the brake shaft at the output end. The brake shaft should be able to turn at the advertised initial release pressure (+ or - 25 PSI). There will be drag on the shaft. Increase the pressure slowly until the shaft spins freely, this is the full release pressure. As you pressurize the brake, look for signs of leaks which would indicate that the o-rings or back-up rings were damaged during assembly.

Repair Kits Model 98D

NOTE:

Due to the many combinations of torques and release pressures available for the 98D, it is impossible to detail each style and supply a repair kit for each individual model. The information listed in this manual is representative of all 98D brakes. The repair kits listed below will work with all combinations of torque vs. release pressure, input mountings and friction plates. It is entirely possible

*to have "extra" parts left over from the repair kits after you have complete the repair or maintenance. If you are not sure about what is required for your brake and its configuration, please contact **Eskridge, Inc.** sales or engineering department.*

Repair kits listed below are for use with the model 98D multiple disc brake.

Friction Disc Kit, 98D 98-016-2001

01-288-0102 Friction Disc, Stator (11)

Separator Plate Kit, 98D 98-016-2021

01-288-0112 Separator Plate (10)

Seal Kit, 98D 98-016-1061

01-400-0210 Back-up Ring, Piston (1)

01-400-0220 Back-up Ring, Piston (1)

01-402-0010 O-Ring, Mtr., "C" (1)

01-402-0030 O-Ring, Piston

(1)

01-402-0690 O-Ring, Piston

(1)

01-402-0700 O-Ring, Case Seal (1)

01-405-0640 Shaft Seal (1)

90-004-1391 Gasket, SAE "C" 4bolt(1)

98-004-1112 Gasket, SAE "D" 4bolt(2)

Master Rebuild Kit, 98D 98-015-3001

01-100-0231 Bearing

(1)

98-016-1061 Seal Kit, 98D (1)

98-016-2001 Friction Disc Kit, 98D(1)



EFFECTIVE DATE: 9-13-94

STARTING SERIAL NO.: 36992

Model 98D

ITEM	QTY	PART NO.	DESCRIPTION
1	1	98-004-1014	CASE
2	1	98-004- 'A'	COVER
3	1	98-004-1032	PISTON
4	1	98-004-1043	SHAFT
5	*	98-004-1121	SPACER
6	1	01-100-0231	BEARING
7	8	01-150-0030	SOC.HD. CAP SCR. (1/2-13 X 1.25 GR8)
8	1	01-160-0050	RETAINING RING
9	1	01-160-0060	RETAINING RING
10	1	01-208-0020	HOLLOW HEX PLUG - (7/16-20)
11	*	01-261-0501	SPRING
12	*	01-288-0102	FRICTION DISC
13	*	01-288-0112	SEPARATOR PLATE
14	1	01-400-0210	BACKUP RING
15	1	01-400-0220	BACKUP RING
16	1	01-402-0030	O-RING
17	1	01-402-0690	O-RING
18	1	01-402-0700	O-RING
19	1	01-405-0640	SEAL

COVER	PART NO.
SAE 'C' 4-BOLT	98-004-1074
SAE 'D' 4-BOLT	98-004-1024

GASKET	PART NO.
SAE 'C' (4-BOLT)	90-004-1391
SAE 'D' (4-BOLT)	98-004-1112

O-RING	PART NO.
SAE 'C'	01-402-0010

INPUT SPLINE ADAPTER	PART NO.
14T 12/24 SPLINE	98-005-1141

OPTIONAL KITS	PART NO.	ITEMS INCLUDED
SEAL KIT	98-016-1061	14, 15, 16, 17, 18, 19, 98-004-1112 (2 PCS.), 90-004-1391
FRICTION DISC KIT	98-016-2001	12 (11 PCS)
SEPARATOR PLATE KIT	98-016-2021	13 (10 PCS)
MASTER REBUILD KIT	98-015-3001	6, SEAL & FRICTION KITS

NOTES:

1. QUANTITY OF SPRINGS IS DETERMINED BY SPECIFIC BRAKE REQUIREMENTS.
2. TOTAL QUANTITY OF SEPARATORS (ITEM 13) AND SPACERS (ITEM 5) MUST EQUAL 10. QUANTITY OF FRICTION DISCS (ITEM 12) EQUALS QUANTITY OF SEPARATOR PLATES (ITEM 13) PLUS 1.
3. A FULL-COMPLEMENT BRAKE INCLUDES 10 SEPARATOR PLATES (ITEM 13), 11 FRICTION DISCS (ITEM 12), 0 SPACERS (ITEM 5), AND 14 SPRINGS (ITEM 11).

M: \SERV\X98DOA

DATE 10/05/94

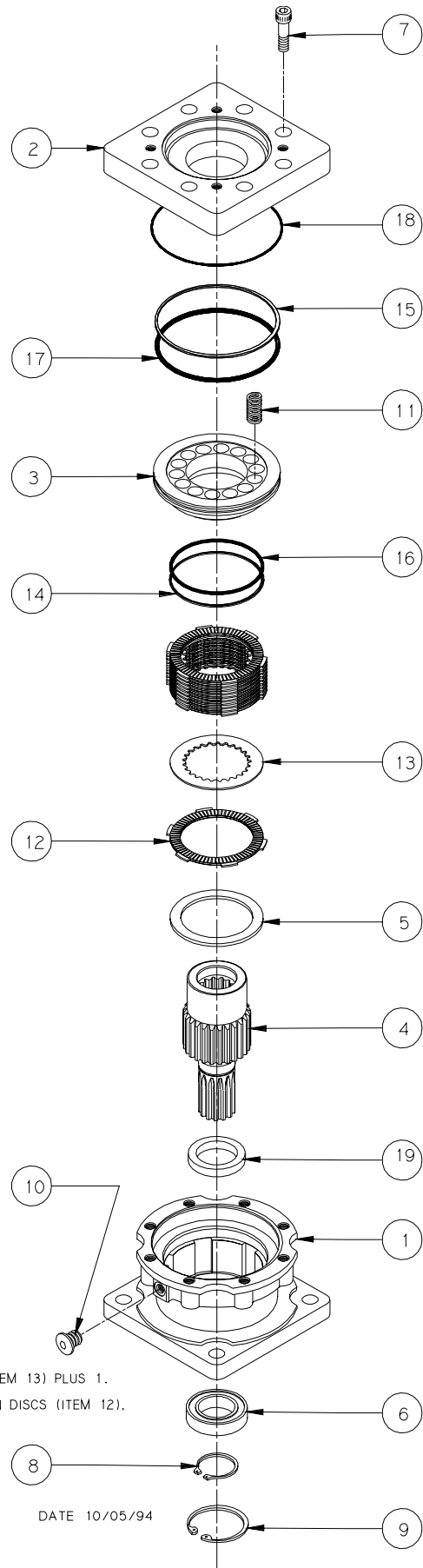

PRODUCT WARRANTY

ESKRIDGE, INC. ("Eskridge") warrants to its original purchaser ("Customer") that new component parts ("Parts") sold by Eskridge to the Customer will be free of defects in material and workmanship and will conform to standard specifications set forth in current Eskridge sales literature or to any custom specifications of the Customer acknowledged in writing by Eskridge, **SUBJECT TO THE FOLLOWING QUALIFICATIONS AND LIMITATIONS:**

- 1) Prior to placing warranted Parts in service, the Customer shall provide proper storage such that foreign objects (e.g., rain or debris) cannot enter any Parts via entry ports which are normally closed during operation.
- 2) If Parts requiring motorized power for operation are received from Eskridge without a motor, documentation must be available indicating proper lubrication upon placement of the Parts in service.
- 3) The Customer must notify Eskridge in writing of any claim for breach of this warranty promptly after discovery of a defect and in any event prior to the termination of the warranty period, which shall commence when a unit is placed in service and shall expire upon the earlier of (i) the expiration of twelve (12) months from the date of Commencement of Service (as defined in Paragraph 4) (ii) the completion of one thousand (1,000) hours of service of the Parts (iii) the expiration of six (6) months after the expiration of any express warranty relating to the first item of machinery or equipment in which the Parts are installed or on which it is mounted, or (iv) the installation or mounting of the Parts in or on an item of machinery or equipment other than the first such item in which the Parts are installed or on which the Parts are mounted.
- 4) Parts shall be deemed to have been placed in service (the "Commencement of Service") at the time the machinery or equipment manufactured or assembled by the Customer and in which the Parts are installed or on which the Parts are mounted is delivered to the Customer's dealer or the original end-user, whichever ever receives such machinery or equipment first.
- 5) This warranty shall not apply with respect to Parts which, upon inspection by Eskridge, show signs of disassembly rework, modifications or improper installation, mounting, use or maintenance.
- 6) Eskridge makes no warranty in respect to hydraulic motors mounted on any Parts. Failure of any such motor will be referred to the motor manufacturer.
- 7) Claims under this warranty will be satisfied only by repair of any defect(s) or, if repair is determined by Eskridge in its sole, absolute and uncontrolled discretion to be impossible or impractical, by replacement of the Parts or any defective component thereof. No cash payment or credit will be made for defective materials or workmanship. **IN NO EVENT SHALL ESKRIDGE BE LIABLE FOR INCIDENTAL OR CONSEQUENTIAL DAMAGES OF ANY KIND OR NATURE, WHICH DAMAGES ARE HEREBY EXPRESSLY DISCLAIMED.**
- 8) From time to time, Eskridge may make changes in the component parts manufactured by it without incorporating such changes in the component parts previously shipped. Such changes shall not constitute an admission by Eskridge of any defects or problems with previously manufactured component parts.
- 9) All freight charges on Parts returned for warranty service are the responsibility of the Customer.

THE FOREGOING WARRANTY IS THE SOLE WARRANTY MADE BY ESKRIDGE WITH RESPECT TO ANY PARTS, AND IS IN LIEU OF ANY AND ALL OTHER WARRANTIES, EXPRESSED OR IMPLIED. THERE ARE NO WARRANTIES WHICH EXTEND BEYOND THE DESCRIPTION ON THE FACE HEREOF. WITHOUT LIMITING THE GENERALITY OF THE FOREGOING, ESKRIDGE EXPRESSLY DISCLAIMS ANY IMPLIED WARRANTY OF MERCHANTABILITY OR FITNESS FOR ANY PARTICULAR PURPOSE, REGARDLESS OF ANY KNOWLEDGE ESKRIDGE MAY HAVE OF ANY PARTICULAR USE OR APPLICATION INTENDED BY THE PURCHASER. THE SUITABILITY OR FITNESS OF THE PARTS FOR THE CUSTOMER'S INTENDED USE, APPLICATION OR PURPOSE AND THE PROPER METHOD OF INSTALLATION OR MOUNTING MUST BE DETERMINED BY THE CUSTOMER.

WARRANTY RETURN POLICY

- 1) All Parts shall be returned freight prepaid.
- 2) Any Parts qualifying for warranty will be repaired with new Parts free of charge (except for freight charges as provided above).
- 3) If parts are found to be operable, you have two options:
 - a. The Parts can be returned to you with a service charge for inspection, cleaning, and routine replacement of all rubber components and any other parts that show wear; or
 - b. We can dispose of the Parts at the factory if you do not wish it to be returned.

NOTE: Any order of Parts by customer shall only be accepted by Eskridge subject to the terms stated herein. Any purchase order forms used by Customer (to accept this offer to sell) which contain terms contrary to, different from, or in addition to the terms herein shall be without effect, and such terms shall constitute material alteration of the offer contained herein under K.S.A 84-2-207 (2)(b), and shall not become part of the contract regarding the sale of the Parts.

OTHER ESKRIDGE PRODUCTS

PLANETARY GEARBOXES

MODEL

20/28 SERIES
36/50 SERIES
60 SERIES
100 SERIES
130 SERIES
150 SERIES
225 SERIES
600 SERIES
1000 SERIES

TORQUE RATING

MAX. INTERMITTENT

20,000-28,000 IN-LBS
36,000-50,000 IN-LBS
60,000 IN-LBS
100,000 IN-LBS
120,000 IN-LBS
150,000 IN-LBS
225,000 IN-LBS
600,000 IN-LBS
1,000,000 IN-LBS

MULTIPLE DISC BRAKES

90B SAE B
90BA SAE B ADJUSTABLE TORQUE
92B SAE B LOW PROFILE
93 FOR NICHOLS MOTORS
95C SAE C
95W WHEEL MOUNT
98D SAE D

OUTPUT TORQUE

TO 4,800 IN-LBS
TO 4,800 IN-LBS
TO 2,800 IN-LBS
TO 6,100 IN-LBS
TO 12,000 IN-LBS
TO 21,000 IN-LBS
TO 25,000 IN-LBS

PLANETARY AUGER DRIVES (DIGGERS)

D36 MODELS 1600, 2000 & 2800
76 MODELS BA & BC, TWO SPEED
77 MODELS BA, BC & BD
78 MODELS 35 & 48, TWO SPEED
74 MODELS 38 & 51, TWO SPEED

TORQUE RATING

1,600-4,500 FT-LBS
8,000-12,500 FT-LBS
6,000-12,500 FT-LBS
9,000-12,500 FT-LBS
16,500-20,000 FT-LBS



1900 Kansas City Road
Olathe, Kansas 66061
phone (913) 782-1238
fax (913) 782-4206

Your nearest Eskridge Distributor is:

WEBSITE: www.eskridgeinc.com
E-MAIL: sales@eskridgeinc.com

