

MODEL 93-120

Multiple Disc Brake Service & Repair Manual

EFFECTIVE FOR:

S/N: 14926 - UP

DATE: 09/01/89 - UP

Part Number & Technical Information

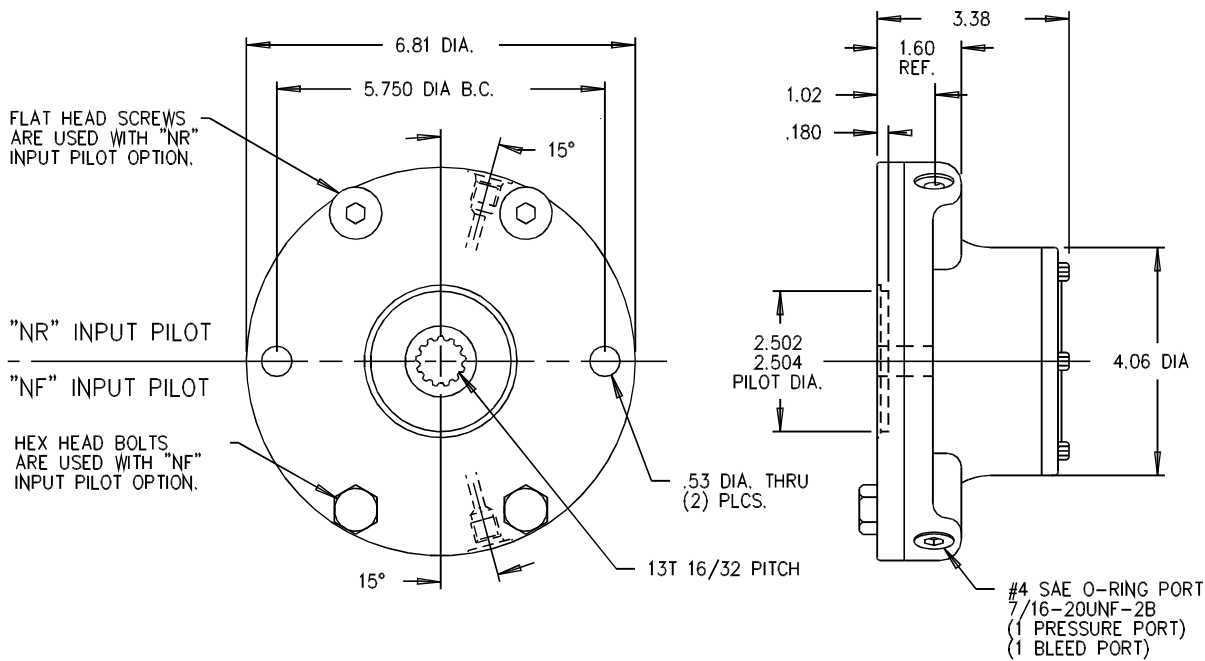

<p>Maximum pressure 3,000 PSI</p> <p>Maximum continuous pressure 3,000 PSI</p> <p>Maximum speed 3,900 RPM</p> <p>Shaft splines 30° involute, flat root side fit per ANSI B92.1-1970 Internal-class 7 External-class 5</p>	<p>Maximum operating temperature 170°F</p> <p>Volume of oil to release brake .50 cu. in.</p> <p>Approximate weight 15 lbs.</p> <p>Breakaway torque may vary +/- 10% from specified ratings. Use of fluids other than ATF type F must be compatible with internal seals. Wet brake torque based on ATF-F fluid in friction plate cavity. Use only mineral base hydraulic oil to release brake. Bolt brake to motor before pressurizing above 300 PSI.</p>
---	--

Part Number Information

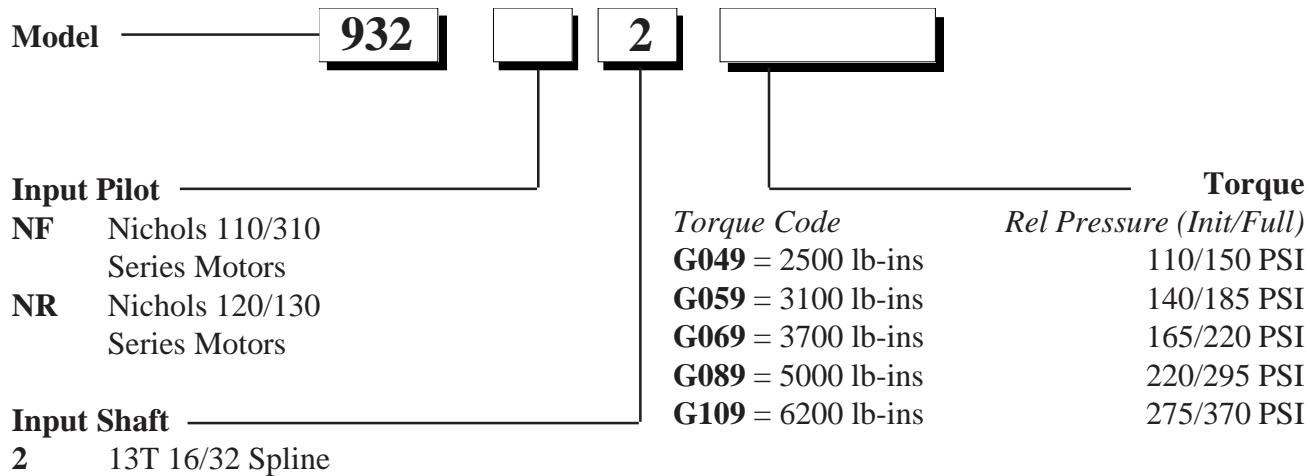

Model 93-120 Service Manual

The Model 93-120 Series Eskridge brake is a spring applied, hydraulically released, multiple disc parking brake. The 93-120 is designed with wet organic friction plates for failsafe operations. Dry bronze friction plates are available as an option.

All the brakes are individually tested at the factory for function, leaks, and static breakaway torque. A failsafe brake should be used only when the requirement is a minimum static holding torque.

Temperature, wear, and contamination of the friction surfaces will affect the performance of the brake and should be

taken into consideration when specifying a required torque rating. Care should be taken to avoid damaging the splines or mounting surfaces during installation.

The model 93-120 is not intended for use in dynamic applications.

Brake operation should be tested during normal service operation. Brake inspection and service should be part of the normal service and maintenance schedule of the equipment or vehicle in which it is used. Any loss of holding torque requires the removal, inspection and replacement of suspect components.

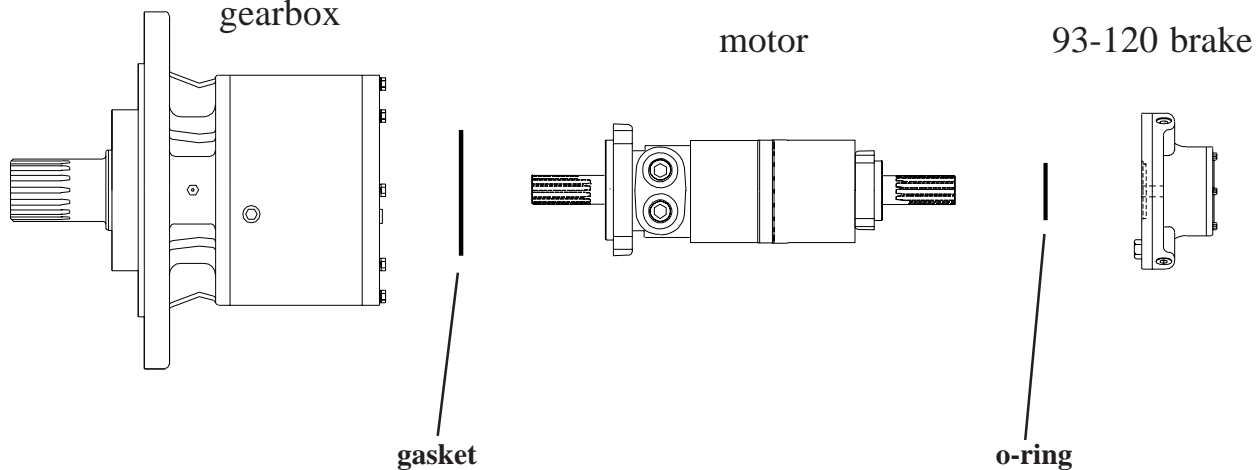

WARNING: While working on this equipment, wear adequate protective clothing, hearing, eye, and respiratory protection. Use safe lifting procedures.

Installation

NOTE: Before beginning installation procedures, visually inspect brake mounting flanges and shaft splines for damage during shipping.

- 1) Position brake and motor for mounting and to orient the bleed and release ports as required. If mounted with shaft horizontal, the bleed port should be at top. It might be necessary to release brake before it can be rotated to align mounting holes. If so, follow instructions in steps 5 and 6 prior to applying release pressure!
- 2) Use only SAE grade 5 (or better) fasteners for mounting brake and motor.
- 3) Allow at least one bolt diameter of thread engagement when selecting fastener lengths. Be sure fasteners will not bottom out

- when fully tightened.
- 4) See torque chart below for torque values.
- 5) Remove plastic protective plug from pressure port of brake and attach a hydraulic pressure line with a 7/16-20UNF-2A straight thread o-ring fitting. Use only mineral based hydraulic oil to test and operate the brake.
- 6) Apply low pressure (20-30 PSI) to brake release port. Loosen hollow hex plug (**ITEM 13**) opposite pressure port just enough to allow air to bleed from between piston o-rings. After air has been bled from brake, remove pressure, tighten plug.

TORQUE IN FT - LBS				
THREAD SIZE	SAE GRADE 5		SAE GRADE 8	
	DRY	LUBED	DRY	LUBED
3/8-16	30	23	45	35
1/2-13	75	55	110	80
5/8-11	150	110	220	170
3/4-10	260	200	380	280

Model 93-120 Service Manual

Disassembly

1) If end cap bearing (**ITEM 9**) or base gasket (**ITEM 8**) need to be replaced, read note and follow step 2. Otherwise, skip to step 3.

NOTE: When inverting brake in step number 2, input end must be capped off with motor or plastic protective closure (used during shipping) to prevent fluid loss. If fluid loss occurs, additional fluid must be added back into brake before operation. To add fluid media*, fully reassemble brake and turn with input facing upward. Remove cover and piston (**DISASSEMBLY steps 4 through 9**) and pour fluid over friction plates until fluid level is even with top friction disc (**ITEM 14**).

2) To replace the end cap bearing or base gasket, it is not necessary to remove cover. Invert the brake and remove the six capscrews (**ITEM 12**). Remove the end cap (**ITEM 3**). Base gasket or bearing may now be removed. When reassembling, torque the capscrews (**ITEM 12**) to 45 in-lbs.

3) Remove any plugs and fittings from the brake pressure and bleed ports. Drain, or blow out, as much hydraulic oil as possible from the brake into a suitable container for proper disposal.

4) Place brake on stable work platform. Support the brake so it won't fall over.

5) Remove the four capscrews (**ITEM 11**) from input end of brake. The capscrews and cover (**ITEM 2**) are under spring load. The capscrews should be loosened gradually and uniformly.

6) Remove cover. This will expose the internal components of the brake. The case seal o-ring (**ITEM 7**) will be attached to the case (**ITEM 1**). Inspect the o-ring and replace with a new one if worn or damaged.

7) Note the color, number, and spacing of the springs (**ITEM 20**) then remove them from piston (**ITEM 4**). Inspect springs and replace with new ones if damaged, broken or discolored from heat.

8) Remove thrust race (**ITEM 10**) from top of shaft (**ITEM 5**).

9) Apply low pressure (20-30 PSI) to the brake release port while holding one hand on top of the piston (**ITEM 4**) and springs. The air will force the piston out of the case.

10) Note arrangement of friction discs (**ITEM 14**), separator plates (**ITEM 15**), and spacers (**ITEM 6**).

11) Remove friction discs, separator plates and spacers. Any friction discs or separator plates that are damaged, warped, or excessively worn should be replaced with new ones.

12) Inspect brake shaft splines and bearing journals for abnormal wear or damage.

13) Remove o-rings (**ITEMS 18 & 19**) and back-up rings (**ITEMS 16 & 17**) from piston. Replace with new ones if worn or damaged.

Assembly

NOTE: Parts must be clean and dry before assembly. Visually inspect components for damage and abnormal wear. Do not use damaged or worn parts.

1) Place brake case (**ITEM 1**) on a stable work platform, small side down.

2) Install the end cap bearing (**ITEM 9**) and shaft (**ITEM 5**).

3) If the brake uses spacers (**ITEM 6**), install them.

4) Install separator plates (**ITEM 15**) and friction discs (**ITEM 14**) in exactly the same order as they were removed. There should be a friction disc on the top and bottom of the stack. Do not place a separator plate next to the piston. *Be careful not to contaminate the friction disc or separator plate surfaces with dirt, grease, or fluid other than the brake was designed to use.*

NOTE: If installing new friction discs, soak all discs in specified fluid media* for approximately 10 minutes before installation.

5) Pour fluid media* over the friction plates until the fluid level is even with top friction disc.

6) If replacing piston o-rings (**ITEMS 18 & 19**) and piston back-up rings (**ITEMS 16 & 17**), be sure o-rings are nearest each other with back-up rings to the outside of the piston (**ITEM 4**). Lightly lubricate piston bores and o-rings. *Take care not to get lubricant onto friction pack.*

7) Gently slide piston into case until larger o-ring touches case. Using a light to medium duty press, push piston completely into bore. This will squeeze the o-rings and back-up rings and set piston against friction pack.

Model 93-120 Service Manual

8) Place springs (**ITEM 20**) into spring pockets in piston. Arrange springs in a symmetrical pattern.

9) Install the thrust race (**ITEM 10**) on top of shaft (**ITEM 5**).

10) Install o-ring (**ITEM 7**) around lip on case (**ITEM 1**).

11) Set cover on top of piston, springs, and shaft.

12) Apply a non-hardening thread-locking compound to each cover capscrew (**ITEM 11**) and start each one into the case by hand. Tighten cover capscrews 1/2 turn at a time in a crisscross pattern until cover is tight against the case. Tighten to the torque shown in the chart on page 3. *A light to medium duty press can be used to push the cover down on to the case so the cover bolts can be installed more easily.*

13) The brake is now ready for testing of fit, function and release pressure. Use only mineral based hydraulic oil to test and operate Eskridge multiple disc brakes. ***Bleed brake before pressurizing.*** To test release pressure, be sure one of the two hollow hex plugs (**ITEM 13**) is installed. Connect a hydraulic power source (either a hand pump or port-a-power) to the other brake port. Bleed air from brake, then pressurize the brake slowly to the advertised release pressure, both initial and full. As you pressurize the brake, rotate the brake shaft. The brake shaft should be able to turn at the advertised initial release pressure (+ or - 25 PSI). There will be drag on the shaft. Increase the pressure slowly until the shaft spins freely, this is the full release pressure. As you pressurize the brake, look for signs of leaks which would indicate that the o-rings or back-up rings may have been damaged during assembly.

Tool list

torque wrench
soft-faced hammer
3/8 inch hex key wrench
5/16 inch hex key wrench
small flat tip screwdriver
o-ring lubricant
non-hardening thread-locking compound
bearing installation tool

For release pressure testing:

hydraulic hand pump or port-a-power
with a pressure gauge and 7/16-20 UNF-2A
straight thread o-ring fitting on the pump hose.

* Unless otherwise specified, series 93 brakes use automatic transmission fluid (ATF type F) as a fluid media. ATF-Dextron will give somewhat different torque characteristic. Some brakes are specifically designed to use hydraulic oil, gear lube, or other fluid media.



THIS DRAWING IS EFFECTIVE
 FROM: S/N 14926, SEPT. 1989
 TO: CURRENT
 REF: X93-DE

MODELS					PART NO.	DESCRIPTION
93-110		93-120				
ITEM	QTY 931-NF	QTY 931-NR	QTY 932-NF	QTY 932-NR		
1	-	-	1	1	93-004-0894	CASE - 93-120
1	1	1	-	-	93-004-0884	CASE - 93-110
2	1	-	1	-	93-004-1113	COVER - NF
2	-	1	-	1	93-004-1123	COVER - NR
3	1	1	1	1	93-003-1061	END CAP
4	1	1	1	1	90-004-1182	PISTON
5	-	-	1	1	93-004-1103	SHAFT- 13T (93-120)
5	1	1	-	-	93-004-1083	SHAFT- 13T (93-110)
6	*	*	*	*	90-004-1031	SPACER
7	1	1	1	1	01-402-0580	O-RING SEAL
8	1	1	1	1	90-004-1111	BASE GASKET
9	1	1	1	1	01-100-0200	BEARING
10	1	1	1	1	01-112-0290	THRUST BEARING
11	4	-	4	-	01-150-1390	HHCS (1/2-13 X 1)
11	-	4	-	4	01-150-1440	FH SCS (1/2-13 X 1)
12	6	6	6	6	01-150-1030	SHCS (#10-24 X 3/4)
13	1	1	1	1	01-208-0020	HOLLOW HEX PLUG
14	*	*	*	*	01-288-0010	FRICTION DISC
15	*	*	*	*	01-288-0020	SEPARATOR PLATE
16	1	1	1	1	01-400-0120	BACK-UP RING
17	1	1	1	1	01-400-0140	BACK-UP RING
18	1	1	1	1	01-402-0450	O-RING
19	1	1	1	1	01-402-0470	O-RING
20	*	*	*	*	01-261-0290	SPRING
21	1	1	1	1	01-402-0590	O-RING-MOTOR MOUNT

REPAIR KITS FOR SERIES 93 BRAKES

FRICTION DISC KIT	93-016-1211	
	01-288-0010	FRICTION PLATES (8)
SEPARATOR PLATE KIT	93-016-1221	
	01-288-0020	SEPARATOR PLATE (11)
SEAL KIT	93-016-1181	
	01-400-0120	BACK-UP RING, PISTON (1)
	01-400-0140	BACK-UP RING, PISTON (1)
	01-402-0450	O-RING, PISTON (1)
	01-402-0470	O-RING, PISTON (1)
	01-402-0580	O-RING, CASE SEAL (1)
	01-402-0590	O-RING, MOTOR PILOT (1)
	90-004-1101	GASKET, COVER (1)
	90-004-1111	GASKET, BASE (1)
	90-004-1171	GASKET, MOTOR (1)
MASTER REBUILD KIT	93-015-1311	
	93-016-1211	FRICTION DISC KIT (1)
	93-016-1181	SEAL KIT (1)
	01-100-0120	BEARING (1)

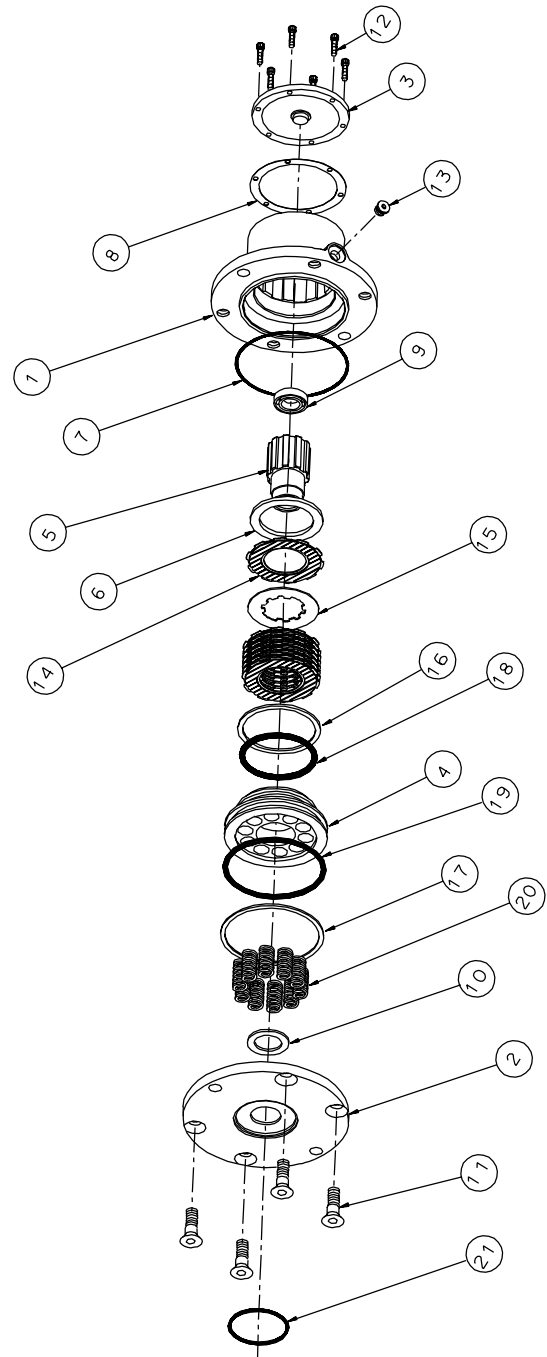

Due to the many combinations of torques and release pressures available for the 93-110, it is impossible to detail each style and supply a repair kit for each individual model. The information listed in this manual is representative of all 93-110 brakes. The repair kits listed below will work with all combinations of torque vs. release pressure, input mountings and friction plates. It is entirely possible to have "extra" parts left over from the repair kits after you have completed the repair or maintenance. If you are not sure about what is required for your brake and its configuration, please contact Eskridge.

* QUANTITIES OF FRICTION DISCS, SEPARATOR PLATES, SPACERS AND SPRINGS MAY VARY DEPENDING ON CUSTOMER'S SPECIFIC TORQUE RATING AND RELEASE PRESSURE REQUIREMENTS. 93-120 BRAKES REQUIRING A FULL COMPLEMENT OF FRICTION DISCS (QTY 10) AND SEPARATOR PLATES (QTY 9) WILL NOT INCLUDE ANY SPACERS (ITEM NO.6). 93-110 BRAKES REQUIRING A FULL COMPLEMENT OF FRICTION DISCS (QTY 7) AND SEPARATOR PLATES (QTY 6) WILL NOT INCLUDE ANY SPACERS (ITEM NO. 6). ONE SPACER TAKES THE PLACE OF ONE FRICTION DISC AND ONE SEPARATOR PLATE.

**QUANTITY OF SPRINGS (10 MAX) DETERMINES BRAKE HOLDING TORQUE AND RELEASE PRESSURE.

Eskridge Product Warranty

ESKRIDGE, INC. ("Eskridge") warrants to its original purchaser ("Customer") that new component parts/units ("Units") sold by Eskridge will be free of defects in material and workmanship and will conform to standard specifications set forth in Eskridge sales literature current at the time of sale or to any custom specifications acknowledged by written Customer approval of drawings, SUBJECT TO THE FOLLOWING QUALIFICATIONS AND LIMITATIONS:

1. Prior to placing Units in service, the Customer shall provide proper storage such that foreign objects (e.g., rain or debris) cannot enter any Units via entry ports which are normally closed during operation.
2. The Customer must notify Eskridge in writing of any claim for breach of this warranty promptly after discovery of a defect. The warranty period shall commence when a unit is placed in service and shall expire upon the earlier of
 - a. the expiration of twelve (12) months from the date of Commencement of Service (as defined in Paragraph 4)
 - b. the completion of one thousand (1000) hours of service of the Units
 - c. the expiration of six (6) months after the expiration of any express warranty relating to the first item of machinery or equipment in which the Units are installed or on which it is mounted, or
 - d. the installation or mounting of the Units in or on an item of machinery or equipment other than the first such item in which the Units are installed or on which the Units are mounted.
3. Units shall be deemed to have been placed in service (the "Commencement of Service") at the time the machinery or equipment manufactured or assembled by the Customer and in which the Units are installed or on which the Units are mounted is delivered to the Customer's dealer or the original end-user, which ever receives such machinery or equipment first.
4. This warranty shall not apply with respect to Units which, upon inspection by Eskridge, show signs of disassembly, rework, modifications, lack of lubrication or improper installation, mounting, use or maintenance.
5. Eskridge makes no warranty in respect to hydraulic motors mounted on any Units. Failure of any such motor will be referred to the motor manufacturer.
6. Claims under this warranty will be satisfied only by repair of any defect(s) or, if repair is determined by Eskridge in its sole, absolute and uncontrolled discretion to be impossible or impractical, by replacement of the Units or any defective component thereof. No cash payment or credit will be made for defective materials, workmanship, labor or travel. IN NO EVENT SHALL ESKRIDGE BE LIABLE FOR INCIDENTAL OR CONSEQUENTIAL DAMAGES OF ANY KIND OR NATURE, FOR WHICH DAMAGES ARE HEREBY EXPRESSLY DISCLAIMED.
7. From time to time, Eskridge may make design changes in the component Units manufactured by it without incorporating such changes in the component Units previously shipped. Such design changes shall not constitute an admission by Eskridge of any defects or problems in the design of previously manufactured component Units.
8. All freight charges on Units returned for warranty service are the responsibility of the Customer.

Warranty Return Policy

1. Any part/Unit(s) returned to Eskridge must be authorized by Eskridge with an assigned return (CSR) number.
2. All Units shall be returned freight prepaid.
3. Any Units qualifying for warranty will be repaired with new parts free of charge (except for freight charges to Eskridge as provided above).
4. If Units are found to be operable, you have two options:
 - a. The Units can be returned to you with a service charge for inspection, cleaning, and routine replacement of all rubber components and any other Units that show wear;
 - b. We can dispose of the Unit(s) at the factory if you do not wish it to be returned.

NOTE: Any order of Units by customer shall only be accepted by Eskridge subject to the terms stated herein. Any purchase order forms used by Customer (to accept this offer to sell) which contain terms contrary to, different from, or in addition to the terms herein shall be without effect, and such terms shall constitute material alteration of the offer contained herein under K.S.A 84-2-207 (2)(b), and shall not become part of the contract regarding the sale of the Units.

The foregoing warranty is the sole warranty made by Eskridge with respect to any Units and is in lieu of any and all other warranties, expressed or implied. There are no warranties which extend beyond the description on the face hereof without limiting the generality of the foregoing, Eskridge expressly disclaims any implied warranty of merchantability or fitness for any particular purpose, regardless of any knowledge Eskridge may have of any particular use or application intended by the purchaser. The suitability or fitness of the Units for the customer's intended use, application or purpose and the proper method of installation or mounting must be determined by the customer.

OTHER ESKRIDGE PRODUCTS

Planetary Gear Drives

<u>SERIES</u>	<u>TORQUE RATING</u>
	MAX. INTERMITTENT
20/28 SERIES	20,000 - 28,000 IN-LB
50 SERIES	50,000 IN-LB
65 SERIES	60,000 IN-LB
100 SERIES	100,000 IN-LB
130 SERIES	130,000 IN-LB
150 SERIES	150,000 IN-LB
250 SERIES	250,000 IN-LB
600 SERIES	600,000 IN-LB
1000 SERIES	1,000,000 IN-LB

Multiple Disc Brakes

<u>SERIES</u>	<u>TORQUE RATING</u>
90B SAE B	TO 4,800 IN-LB
90BA SAE B ADJUSTABLE TORQUE	TO 4,800 IN-LB
92B SAE B LOW PROFILE	TO 2,800 IN-LB
93 FOR NICHOLS MOTORS	TO 6,100 IN-LB
95C SAE C	TO 12,000 IN-LB
95W SAE C WHEEL MOUNT	TO 21,000 IN-LB
98D SAE D	TO 25,000 IN-LB

Diggers (Planetary Auger Drives)

<u>SERIES</u>	<u>TORQUE RATING</u>
D50 MODELS 1500, 2500 & 5000	1,500 - 5,000 FT-LB
76 MODELS BA & BC, TWO SPEED	8,000 - 12,500 FT-LB
77 MODELS BA, BC & BD	6,000 - 12,500 FT-LB
78 MODELS 35 & 48, TWO SPEED	9,000 - 12,500 FT-LB
75 MODELS 38 & 51, TWO SPEED	16,500 - 20,000 FT-LB

